



The Zimbabwe Bush Pump: Mechanics of a Fluid Technology

Author(s): Marianne de Laet and Annemarie Mol

Source: *Social Studies of Science*, Vol. 30, No. 2, (Apr., 2000), pp. 225-263

Published by: Sage Publications, Ltd.

Stable URL: <http://www.jstor.org/stable/285835>

Accessed: 29/07/2008 09:06

Your use of the JSTOR archive indicates your acceptance of JSTOR's Terms and Conditions of Use, available at <http://www.jstor.org/page/info/about/policies/terms.jsp>. JSTOR's Terms and Conditions of Use provides, in part, that unless you have obtained prior permission, you may not download an entire issue of a journal or multiple copies of articles, and you may use content in the JSTOR archive only for your personal, non-commercial use.

Please contact the publisher regarding any further use of this work. Publisher contact information may be obtained at <http://www.jstor.org/action/showPublisher?publisherCode=sageltd>.

Each copy of any part of a JSTOR transmission must contain the same copyright notice that appears on the screen or printed page of such transmission.

JSTOR is a not-for-profit organization founded in 1995 to build trusted digital archives for scholarship. We work with the scholarly community to preserve their work and the materials they rely upon, and to build a common research platform that promotes the discovery and use of these resources. For more information about JSTOR, please contact support@jstor.org.

ABSTRACT In this paper we investigate the intricacies of an admirable water pumping device – the Zimbabwe Bush Pump ‘B’ type – so as to find out what makes it an ‘appropriate technology’. This turns out to be what we call the ‘fluidity’ of the pump (of its boundaries, or of its working order, and of its maker). We find that in travelling to intractable places, an object that isn’t too rigorously bounded, that doesn’t impose itself but tries to serve, that is adaptable, flexible and responsive – in short, a fluid object – may well prove to be stronger than one which is firm. By analyzing the success and failure of this device, its agency and the way in which it shapes new configurations in the Zimbabwean socio-technical landscape, we partake in the current move in science and technology studies to transform what it means to be an *actor*. And by mobilizing the term *love* for articulating our relation to the Bush Pump, we try to contribute to shaping novel ways of ‘doing’ normativity.

Keywords agency, appropriate technology, design, heroic actorship, modesty, normativity, waterpumps

The Zimbabwe Bush Pump: Mechanics of a Fluid Technology

Marianne de Laet and Annemarie Mol

This is a paper about water pumps. More precisely, it is about a *particular* hand water pump: the Zimbabwe Bush Pump ‘B’ type. The paper is not critical, but neither is it neutral. For we happen to like, no, even better, to *love* the Zimbabwe Bush Pump in all of its many variants. But even if affection moves our writing, this is not an exercise in praise. Rather, we want to analyze the specific quality that attracts us to the Zimbabwe Bush Pump. This turns out to be its *fluidity*. So in what follows we lay out the various ways in which this piece of technology, so advanced in its simplicity, is fluid in its nature.¹

The Zimbabwe Bush Pump is solid and mechanical and yet, or so we will argue, its *boundaries* are vague and moving, rather than being clear or fixed. Likewise, the question as to whether or not the Bush Pump actually *works*, as technologies are supposed to, can only rarely be answered with a clear-cut ‘yes’ or ‘no’. Instead, there are many grades and shades of ‘working’; there are adaptations and variants. Thus the fluidity of the pump’s working order is not a matter of interpretation. It is built into the technology itself.²

This is not an accident. The Bush Pump is made that way. It is made that way by a modest inventor. For, to our great pleasure, the Bush Pump

comes with a non-classical hero who is as active as can be, and yet who makes no claims to *heroic* actorship. To the extent that we know him, he is (how to say this without getting personal or, even less appropriate, ironic?) an ideal man. For he too is fluid, *dissolving* into his surroundings. The one kind of activity which he firmly stands for is attending, being attuned, and adapting to what happens to the Bush Pump in the world-out-there.³

In technology studies, much has been written about the enormous difficulty of moving technologies, of transferring them from one site to another. For instance, in her case studies Madeleine Akrich has shown beautifully how the element that leads to the collapse of a carefully built network of machines, skills and social relations may be tiny. A minute bug eating cotton stalks stored in a warehouse is sufficient to harm the transfer of a cooking device from Sweden (where it burned sawmill waste) to Nicaragua. The successful move of a 'Gasogene' from its manufacturer in France to Costa Rica, where it ought to generate power, is stopped in its tracks by attempts to feed it with a type of wood it hadn't met before. While the transport of a photoelectric lighting kit from France where it is made, to Africa where it is intended for use, is impeded by the fact that it depends on a non-standard type of plug – that isn't available in Africa.⁴

Stories like these bring out the striking adaptability of the Zimbabwe Bush Pump. Perhaps in this it is like the clinical diagnosis of anaemia in medicine which, unlike its laboratory-based cousin, reveals a flexibility that allows it to travel almost anywhere. As has been argued elsewhere, the adaptability of clinical diagnostic methods suggests that they hold together as a *fluid*, rather than as a network.⁵ Something similar might be true for other technologies that transport well. Therefore we mobilize the metaphor of the *fluid* here to talk of the Bush Pump. In doing so we hope to contribute to an understanding of technology that may be of help in other contexts where artefacts and procedures are being developed for intractable settings which urgently need working tools. Because in travelling to 'unpredictable' places, an object that isn't too rigorously bounded, that doesn't impose itself but tries to serve, that is adaptable, flexible and responsive – in short, a fluid object – may well prove to be stronger than one which is firm [Morgan, 160].

Our contention that technology is likely to travel well when it is fluid is not only relevant for the Zimbabwean villages *for* (and – as we contend – *by*) which the Bush Pump was designed. We write about it *here* because the Bush Pump may have something to tell readers of *Social Studies of Science* as well: it may help the current move in science and technology studies, to transform what it means to be an *actor*. For, as has been argued by many, the 'actor' that sociology has inherited from philosophy, *Rational Man* – a well-bounded, sane and centred *human* figure – is in urgent need of an update. At first sight it may seem a tall order for the Bush Pump to provide such an update; a pump, after all, is neither human nor rational. But then again: the Bush Pump *does* all kinds of things, and we will explore some of its *activities*. Arguably, it *acts* as an actor. Thus subsuming the pump under

the category of 'actor' broadens the category, allowing it to include non-human, non-rational entities.⁶

But there is more. Our new actor, the Bush Pump, is not well-bounded but entangled, in terms of both its performance and its nature, in a variety of worlds. These begin to change more or less dramatically as soon as the Bush Pump stops acting. Yet it is not clear *when* exactly the Pump stops acting, when it achieves its aims, and at which point it fails and falters. That is what we also mean to capture when we use the term *fluid*. If the Bush Pump may be called an 'actor' despite its fluidity, then 'actors' no longer (or not always) *need* the clear-cut boundaries that come with a stable identity. In short and to summarize: the Bush Pump is not a solid character. Not only can actors be non-rational and non-human; they can also – or so we hope to demonstrate – be fluid without losing their agency.⁷

With this assertion we enter a theoretical debate in science and technology studies which is to do with the nature, the power and the intentions of the actor in actor-network approaches.⁸ And we carry this debate a step further when we talk about the Bush Pump's designer. Obviously, the Bush Pump's designer is a human actor: but, in this text, we subject him, too, to our theoretical purposes. We draw his image so that it contrasts with the *managerial vision* of the heterogeneous engineer.⁹ The latter has been depicted as a network builder, who gains prominence by successfully marshalling credit for the work done by assemblies of people and assemblages of things. Louis Pasteur (in the portrait by Bruno Latour) is a case in point.¹⁰ Granted the honour of having 'conquered' an infectious disease plaguing French cows, Pasteur is present in all French towns – if not as a statue, then at least as a street. Latour's study shifts the attention from the general to the army; from Pasteur to all other elements that worked just as hard in eradicating the disease.

There is, however, a next step to be made. For even if Latour's work shifts Pasteur out of the centre by pointing to the network he needs, it also suggests (or has been read as suggesting) that innovation, even if it turns out to be the work of a large army, *does* need a general in order to spread out. This Machiavellian reading of Latour says that technologies depend on a power-seeking strategist who, given a laboratory, plots to change the world. And this is where the Bush Pump and its designer come in. They allow us to frame a different vision. The *success* of a technology does not necessarily depend on an engineer who masters the situation and subtly subdues everyone and everything involved. A serviceable (or even submissive) inventor may help spread technologies just as well – or even better. Effective actors need not stand out as solid statues but may fluidly dissolve into whatever it is they help achieve.

The Scope of the Object: The Boundaries of the Zimbabwe Bush Pump 'B' Type Explored

The designer knows when he has reached perfection, not when there is no longer anything to add, but when there is no longer anything to take away. [Morgan, 160]

So the object we invite you to examine with us is the Zimbabwe Bush Pump.¹¹ And our first questions are: what does it look like? How big is it? What forms a part of it? Where are its boundaries? How might we best describe it?

The Zimbabwe Bush Pump has existed for more than half a century, but it has not remained the same. It is not an immutable but a changeable object, that has altered over time and is under constant review. The current model results from restyling and improving an older manually-operated water pump that was first designed in 1933 by Tommy Murgatroyd in what was then Rhodesia's Matabeleland. The experimenting and changing are still going on.

When new models come into being, the old ones do not necessarily disappear. The original pump has proved to be a technology appropriate to the conditions of the African bush: some of Murgatroyd's Bush Pumps installed in the 1930s are still working in Zimbabwe today [Morgan, 153]. Other models succeeded the original, and some of these also survive. And while many different types of manual water pumps are available, it is the newest model Bush Pump – the 'B' type – that is spreading most rapidly in Zimbabwe right now [Morgan, 67].

So the Bush Pump is fluid because it is variable over time. But if we are to describe it we need to pick a version, so we focus on this newest model, the 'B' type. Even if this is the latest model now, it may already be slightly outdated by the time you read this text – though it won't have disappeared from the Zimbabwean villages where it is installed. For the Bush Pump 'B' type may not be made to be immutable, but it *is* made to last.

Pump Head: Topping the Well

Cheerfully blue, you would want a Zimbabwe Bush Pump 'B' type in your own back yard. Originally designed for 'simplicity, durability, and ease of maintenance' [Murgatroyd, paraphrased in Morgan, 154], the current model is attractive and appealing. Its cobalt colour suggests purity, clarity and freshness, the qualities sought for the water that it delivers. And its clean hard lines and compact shape ask you to 'pick me up and install me wherever you fancy. I am cool and easy to use'. This message is not frivolous fantasy on our part. The pump is *meant* to convey messages of this kind. The pump's manufacturer in Harare, V&W Engineering, has found that the tools it makes are most likely to be used if they are brightly coloured: 'We like to paint our products brightly, make them attractive. They work better that way'.^c And together with Dr Morgan, the developer of the 'B' type, the factory has worked hard to enhance the usability of the pump, increasing its durability while also making it cheaper [Morgan, 160].

The Zimbabwe Bush Pump 'B' type consists of a pump head or water discharge unit, a base or pump stand, and a lever. The steel pump stand is bolted to the bore hole casing at one end and to the water discharge unit at the other. The lever is a flexibly fixed wooden block, joined with bolts to

the upper part of the water discharge unit. When the lever is raised and lowered it works the moving parts of the pump. The wooden block is attached to a U-bracket which holds the upper end of the pump rod. Movement of the rod (backwards and forwards, and side to side) is absorbed by two floating washers within the floating-washer housing. These parts form the water discharge unit at the top of the rising main – together they form the stable section of the pump above ground level. Of course, all this is held together by nuts and bolts.

These words don't really describe it properly, do they? Perhaps, then, a drawing will help.

FIGURE 1
Pump Head as Pictured in Instruction Manual

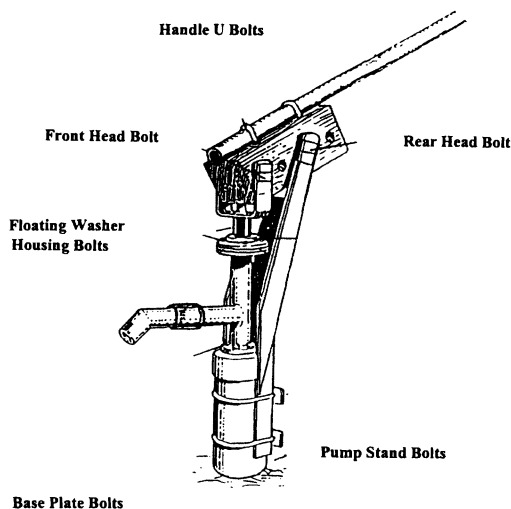

Source: Morgan, op. cit. note 12, 1.

Hydraulics: Down the Well

Together with the words, the drawing in Figure 1 offers a reasonable description of the device. But even so, the pump isn't quite *there* yet, for it has other *invisible* parts beneath the ground, moving and static parts. In his wonderfully rich text on rural water supplies and sanitation in Zimbabwe, Dr Peter Morgan begins his description – another description – of the pump as follows:

The Bush Pump operates on a lift pump principle, the reciprocating action being transferred from the pump head to the cylinder through a series of galvanised steel pump rods running inside a steel pipe (rising main). Most rising mains are made from 50 mm galvanised iron pipe, although 40 mm pipe is becoming more common. Most rods are made of 16 mm mild steel although 12 mm is also used. Pump cylinders are made

of brass and are either 50 mm or 75 mm in diameter. The piston and footvalves are also made of brass. Most piston valves [as well as the seal] are made of leather, but neoprene is becoming more common. [Morgan, 154–55] ¹²

Here, the pump is defined neither in terms of its colour nor by the parts you can see above ground. Instead the story is about its hydraulic components (see Figure 2). It is, after all, the *hydraulic forces* that enable it to pump water out of the ground. As Morgan says:

The functional part of the pump is inside. It is hidden. And it is not all tangible. To you it will be clear how a pump works, because you have at least a basic knowledge of hydraulics. But for people in the rural areas the sudden emergence of water from a new pump is rather a miracle.³

And although our knowledge of hydraulics was a bit rusty, Morgan is right: a quick look at his illustrations helps to clarify how the pump works. To the informed eye another set of pictures brings the underground parts to life – the parts that achieve the miracle of the hand water pump.

So maybe the hydraulic principles, or the components that make those principles work, define the pump? They do, because the hydraulic forces draw water from deep wells to the surface. And the hydraulic principles that it embodies distinguish the Bush Pump from other pumps. For instance, they trace a boundary between the Bush Pump and a common alternative – the Bucket Pump. The Bucket Pump is a bucket-and-windlass device, while the Bush Pump uses pistons, valves and levers. This difference leads to other distinctions: the Bucket Pump is deployed in shallow, open wells and can be used by up to 60 people, while the Bush Pump can be operated in a wide range of well-types and serves up to 250 [Morgan, 68].

But even if its hydraulic principles separate the Zimbabwe Bush Pump ‘B’ type from the Bucket Pump, this does not mean that it is unique. They

FIGURE 2
Hydraulics

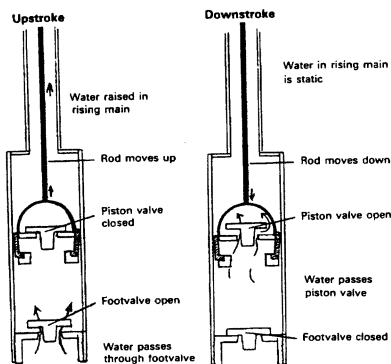

Source: [Morgan, 169].

define the pump – but not by setting it apart from all other pumps. This is because it belongs to a family of pumps with a ‘lever activated lift pump mechanism’.¹³ *Within* this family, the Bush Pump’s specificity lies not in its hydraulic principles, but in its capacity. The Bush Pump’s strokes are more efficient and powerful than those of most other lift pumps; lifting water from wells up to 100 metres deep – which is about twice the depth reached by those other pumps – the Bush pump has exceptional competence. But the difference is not simply a matter of power and efficiency; it also has to do with durability. Made of steel and wood, the Bush Pump is designed to last longer than either of the others, whose major parts are mostly made of PVC. In this respect the solidity of the Bush Pump is more like that of the bucket-and-windlass Bucket Pump.

So the Bush Pump is specific.¹⁴ We can describe it in terms of its difference from other pumps. But the characteristics that distinguish it from each of these also tend to be shared with one or more of the others. For the Bush Pump, ‘*being itself*’ means that it is continuous with a number of others.

Headworks For Health

There it is then, the pump delivered by V&W Engineering: pump head, lever, base and underground parts. But is this it? Have we described and defined our object now? The answer is no, there is a problem, for when it’s unloaded from the truck the Bush Pump yields no water. None whatsoever. It is not a pump.

If it is to work it has to be assembled. It needs to be installed, and installed properly. As a part of this, it needs to be cemented into concrete *headworks* to stop spilled water from finding its way into the well and contaminating it. It also needs a casing to stop the well from collapsing and letting mud, sand and other pollutants fall into it. Only when it is set up in this way does it begin to provide water. But once this has been done it doesn’t simply supply water but something even better: it becomes a source of pure, fresh, *clean* water. And so the Bush Pump turns out to be a technology that provides not just water but also health.¹⁵

As a health-promoting technology, the Bush Pump is not defined by its colour, by its hydraulic principles or by the materials of which it is made, but by a set of *health indicators*. The principal health indicator for assessing devices which extract groundwater is the *E.coli* count. *Escherichia coli* is a bacterium that lives in every human intestine. So long as it stays there, all is usually well: *E.coli* in most of its variants lives harmoniously with *homo sapiens* in most of its variants. It is only when we encounter strains of *E.coli* that are strange to us that we tend to fall ill.¹⁶ So this is what makes *E.coli* a potential risk, in and of itself. More important is the way it works as a signal: if *E.coli* can pass from the human intestine into the water supply, then other bacteria will be able to move with it. And with the water, they may continue their journey to the next organism. And *this* is the health hazard that needs to be avoided.

TABLE 1
Mean *E.coli* Counts for Various Groundwater Sources

Source	Mean <i>E.coli</i> /100ml sample	No. of samples
Poorly protected wells	266.42	233
Upgraded wells	65.94	234
Bucket Pump	33.72	338
Blair Pump	26.09	248
Bush Pump	6.27	281

Source: [Morgan, 253].

Different techniques for obtaining water can be measured and compared in these terms, as indeed they are. For example, a study carried out by the Blair Research Institute in Harare during the rainy season of 1988 gives *E.coli* counts for five different water sources (see Table 1). Unprotected surface water may show *E.coli* counts of over 1000 per 100 ml sample. Figures collected by Zimbabwe's National Master Water Plan in 1988 demonstrate that in that year only 32% of the rural population used improved water sources in the wet season – a figure which climbed a little to 38.7% in the dry season [Morgan, 44]. A comparative study of 25 wells, carried out by the Blair Institute on samples taken in 1984 and 1985, shows a mean *E.coli* count of 475.39 for seven traditional wells (197 probes), 16.69 for eleven Bucket Pumps (261 probes), and 7.67 for seven Bush Pumps (191 probes). In this last study, the mean for the Bucket Pumps is somewhat inflated, because one sample was abnormally contaminated:

The unusually high *E.coli* count for B 10 on 2.4.84 was caused by a defect in the concrete apron which cracked, and also infiltration of contaminated water from a nearby hollow used for making bricks. These problems were corrected. [Morgan, 77] ¹⁷

Apparently a sound *apron*, part of the headworks of a pump, is crucial in reducing *E.coli* counts.¹⁸

Aprons and other features of the headworks are usually made by the future users of a new pump: a collective of villagers builds the headworks and installs the pump. So the pump comes with a simple but very detailed set of instructions (see Appendix 1 for a list). These instructions insist that the borehole must be installed at a higher elevation, and at least 30 metres from latrines and cattle kraals. They detail and illustrate all the steps to be taken in building a concrete slab and water run-off; they give exact measurements for all the parts to be made. Thus the instructions list the various elements a pump needs if it is to provide health by keeping *E.coli* and its colleagues at bay: it needs a bore hole casing which rises at least 500mm above ground level; a concrete apron of thickness 100–150mm; an auger full of fine gravel or 6mm granite chips to be poured into the tube well; a ring of bricks at least two metres wide as a rim for the apron; a water run-off channel at least six metres long that runs down, possibly to a

vegetable garden; concrete of four parts stone, two parts washed river sand and one part cement.¹⁹

These elements and their measurements have been thoroughly tested. The precautions are crucial, both for installing more or less standard headworks, and in translating these into step-by-step instructions, because:

Poorly made concrete headworks can crack, and will allow leakage of waste water from the surface back into the well or borehole. Similarly where handpumps are loosely fitted and worn in such a way that water can drain from the apron through the pump head into the well, then contamination of the well water is inevitable. [Morgan, 18–19]

And once its well is contaminated, the Zimbabwe Bush Pump may still provide water, but it no longer provides health.

Village: Drilling the Well

So the headworks are a crucial part of the pump – of the pump that brings health. But if the pump is to work in *any* of its identities (as a proper mechanism, as a particular system of hydraulics, as a hygienic intervention) it also needs a hole. At this point, it needs to collaborate with another piece of technology: a *tubewell drilling device*.

In Zimbabwe, and increasingly in other African countries, this device is often the ‘Vonder Rig’. Invented and patented by Mr Erwin Von Elling, and manufactured at his plant (which happens to be the same factory where the Zimbabwe Bush Pump is made), the Vonder Rig is hand-driven, portable, durable and bright yellow. It is designed so that the boring of the water hole, like the process of making the headworks and installing the pump, can be almost entirely ‘community-based’.

So communities bore wells. A video distributed by the factory shows that sometimes operating the rig turns into a village feast.²⁰ Village women push the iron crossbar to drive the auger into the ground, while village men sit on the bar to weigh it down and children dance around (see Figure 3). According to the factory, the village is able to participate because the rig is manually operated and not mechanically powered.²¹

FIGURE 3
Community Drilling a Borehole

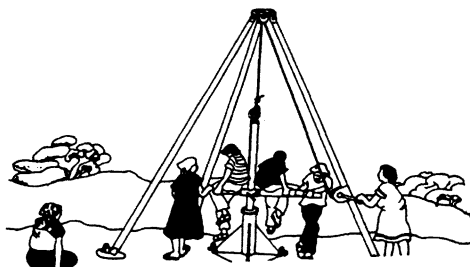

Source: [Morgan, 51].

The one great advantage of the hand operated drilling rig is that it makes full community participation possible at village level. There are many examples in Zimbabwe where the rig is operated fully under control of the villagers, which has an important influence on the success or failure of the final installation.²²

And community participation is not only important in drilling the hole. It is crucial in finding the site in the first place. Some community members have more say in this than others. As a UNICEF worker explained, the *nganga* (especially when doubling as a local water diviner) may be imperative to the working of a pump.²³

Often, wells are drilled by NGOs purely on the basis of geological survey. However, in a country like Zimbabwe such wells do not always work. Even though the water that the well produces may be abundant and clear, and even though the new well may be nearer for its (intended) users than an older one that it is meant to replace, you may see a path traced out in the sand that leads around it. If the village women do not want to use the well, if it has been bored without consulting the *nganga* or was put into operation without his consent, the well is dead. Sometimes literally. There are instances in which a well was bored without the *nganga's* approval and, contrary to all measurements, turned out to be dry. Not a drop of water. And unfortunately, boring wells without consulting the *nganga* has happened all too often, especially when NGOs or governments are determined to keep the siting and boring of the well entirely in their own hands.^d

Morgan and Von Elling have learned this lesson and taken it to heart. Not only do they make a concerted effort to make the pump simple, attractive and easy to use and maintain, but they also state clearly and repeatedly, in instruction manuals and other publications, that local water diviners should be consulted before any decision about the siting of a water hole is made [Morgan, 24].²⁴

Morgan and Von Elling thus suggest that village participation is key to the operation and maintenance of the pump.

In Zimbabwe, village level participation is actively encouraged in all water and sanitation schemes. It is now well established that without this participation, communities cannot generate the commitment for maintenance as they do when they are involved. [Morgan, 106]

So the village not only gets a pump, but it also gets instructions for how to install its water provider. Ideally, it is involved in all aspects of installation: it bores the hole, assembles the pump, constructs the headworks. And, together with the water diviner, it helps to pick the site. The village has joint ownership and collective responsibility for installation, operation and maintenance. As the manuals declare: 'The Zimbabwe Bush Pump Was Designed For Villagers to Maintain Themselves!'.²⁵

This suggests yet another way of describing and setting boundaries around our object. In critical ways, the Zimbabwe Bush Pump includes the villagers that put it together. The pump is nothing without the community

that it will serve. In order to be a pump that (pre)serves a community, it not only needs to look attractive, have properly fixed levers and well-made concrete aprons, it must also be capable of gathering people together and of inducing them to follow well-drafted instructions. It must come with a Vonder Rig and invite people to push bars, sit on them or dance around them. It must seduce people into taking care of it. Thus the boundaries around a community pump may be widely drawn. Indeed, they embrace the community.

National Standards

Community participation is quite the thing in the theory of appropriate technology. It is 1980s' wisdom to design projects, tools and machines whose maintenance, installation and operation are 'community based'.²⁶ In Zimbabwe, this has become national policy.²⁷ From (by some, heavily criticized) 'campfire' projects to the drilling of wells, it is the village community that is the target for government operations, the level of collectivity most commonly addressed, and the unit the administration most strongly seeks to reinforce.²⁸ In Zimbabwean water policy the village is the preferred unit, the standard organization on which intervention is based.²⁹

In this way we arrive at another description of, another identity for, the Zimbabwe Bush Pump. For the pump doesn't simply serve communities, helping to hold them together. It promotes something else as well. As it helps to distribute clean water, it also builds the nation. For though it sometimes pours down all too abundantly in the rainy season, water is scarce in Zimbabwe.³⁰ And health in this country, plagued not only by AIDS and malaria but also by a host of water-borne bacterial diseases, is a precarious policy issue. So while nation-building may involve writing a shared history, fostering a common cultural imagery or promoting a standard language, in Zimbabwe it also has to do with developing an infrastructure for water. This involves a range of activities, from boring new wells and upgrading existing ones, to planning the construction of a pipeline from the mountains to the capital. And not only the government is involved. Universities, NGOs (Non-Governmental Organizations), the GIS (the computerized Geological Information System), the V&W Engineering Company, many active villagers, and the Zimbabwe Bush Pump – all of these also participate.

As it is, there are great social divides in Zimbabwe between those who have plumbing in their houses, those who have water in their yards, and those who have to walk miles to get it. Setting up a national water infrastructure may help to bridge such divides. And government support for buying a pump may link up the village to the state, thereby enlisting villages in what is otherwise likely to remain an abstract nation.³¹ So the Zimbabwe Bush Pump builds the nation. And it does so not only because it provides clean water if it is properly installed. It also helps that it is a local pump – produced in Zimbabwe, designed in Zimbabwe, built with

materials available in Zimbabwe, the Bush Pump complies with standards of quality and strength set in Zimbabwe. It is tailored to local circumstances, to local patterns of use and abuse. Its local origin means that it is well-adapted to the demands of Zimbabwean rural water supplies. And its local manufacture guarantees that spare parts will always be at hand.

In the world of water sanitation policy and development this is rare. As far as we know, Zimbabwe is the only African country that produces its own pump. Relief programmes, like UNICEF's 'Water for the Children', usually carry their own model. This is why one finds water-pumping devices strangely clustered on the world map: trucked all over the globe by relief organizations, pumps end up where these organizations happen to go – rather than near the sites where they are produced. Not so, however, in Zimbabwe. Here, UNICEF (a significant partner in the improvement of Zimbabwe's water infrastructure) was discouraged by the government to employ its usual pump. Buying its first ten 'B' types in 1987 for trials, the organization rapidly converted to the Bush Pump.^a

As a local product the current version – the smaller, lighter, simpler 'B' type Bush Pump – has been one of the government's two standard hand pumps since 1989. It is the model recommended for high-duty settings; that is, it is the pump of choice in all government-sponsored water supply programmes where demand is high. That does not mean that the Bush Pump is Zimbabwe's most frequently used water-lifting device. According to Morgan, there is an estimated total of 100,000 wells or water holes in the country, while (in early 1998) about 32,000 Bush Pumps have been installed – over half of which are 'B' type pumps.³² It *does* mean, however, that other pumps, with the exception of the Bucket Pump (which is the government's low-duty standard) [Morgan, 160], are gradually being phased out. As we write, this phasing out of other pumps has almost been completed.^b

A national standard, the Zimbabwe Bush Pump is a nation-builder that gains strength with each new installation. Meanwhile, the Zimbabwean nation is a pump-builder, in that it oversees and encourages new installations of Bush Pumps. However willing it may be to travel elsewhere,³³ the 'B' type is thus an unmistakably *national* pump (see Figure 4).

A Fluid Pump

In Zimbabwe, the Bush Pump 'B' type has become a national standard because it is a good pump. And now it is an even better pump because it has become a national standard. Sturdy, versatile, effective, locally manufactured, parsimonious, it is easy to service and easy to operate. It is so well-designed and parsimonious that, according to V & W's director, efforts to reverse-engineer and reproduce it always result in a pump that has more parts; that is more complicated, and unnecessarily so. And as Morgan notes, 'the designer knows when he has reached perfection, not when there is no longer anything to add, but when there is no longer anything to take away' [Morgan, 160].

FIGURE 4
A Row of Bush Pumps at V & W Engineering



Source: Photo by Marianne de Laet.

And yet. Even if nothing can be taken from it, it is not clear where this pump ends. For what *is* the Zimbabwe Bush Pump? A water-producing device, defined by the mechanics that make it work as a pump. Or a type of hydraulics that produces water in specific quantities and from particular sources. But then again, maybe it is a sanitation device – in which case the concrete slab, mould, casing and gravel are also essential parts. And while it *may* provide water and health, the Pump can only do so with the Vonder Rig – or some other boring device – and accompanied by manuals, measurements and tests. Without these it is nothing, so maybe they belong to it too. And what about the village community? Is it to be included in the Pump – because a pump has to be set up by a community and cannot be maintained without one? But then again, perhaps the boundaries of the Bush Pump coincide with those of the Zimbabwean nation. For in its modest way this national Bush Pump helps to make Zimbabwe as much as Zimbabwe makes it.

So the Bush Pump ‘B’ type has a number of possible boundaries. A small device in some ways, in other ways it encompasses an entire state. But we are not interested in making claims about its *absolute* size or reach. Instead, we want to insist that the Bush Pump is – descriptively and practically – framed in a range of different ways.³⁴ The fluidity of the Bush Pump’s boundaries, however, does not imply that it is vague or random; that it is *everywhere* or *anything*. For however fluid it may be, the Bush Pump is clearly not a Bucket Pump. And providing healthy water with a pump on a solid concrete slab is not like doing so by building non-flushing, wind-ventilated latrines.³⁵ Digging a well by pushing a bar that is heavy because the men are sitting on it creates a community gathering of a different kind to one that meets to bury a neighbour. Holding a nation together with a pump is not like doing so with gifts of money or the reallocation of land.³⁶ Thus, the Bush Pump’s various boundaries define a limited set of configurations. They each, one might say, *enact* a different Bush Pump. But these different Bush Pumps have in common that they are

indeed a pump – and not a diviner, a rain cloud or a water infrastructure chart.

There it is, then, our pump. Beautifully blue. But is it an *actor*: does it work?

The Workings of the Technology: Successes and Failures of the Zimbabwe Bush Pump

*Children should be taught not to throw stones down the tubewell.*³⁷

All sorts of things can go wrong with a pump. As a technology, the Zimbabwe Bush Pump ‘B’ type is expected to *perform*. It must act, *do* something. It is made to *work*. And it is made to *keep on working*.³⁸ Designed for simplicity, durability, ease of maintenance, and assisted by manuals and instructions, it is created to survive. But despite all this a pump may *stop* working in all sorts of ways. It may become dirty. Its seal may erode. The pipes may wear, rust or come apart. The children may not be properly taught, and throw stones down the well. The community may become disorganized. While the ways in which the pump works are many – it makes water, health, community, a nation – there are just as many ways in which it may fail.

Hydraulics: Down-the-Hole Parts

If the *hydraulics* fail in Bush Pumps, then the pump is in trouble. This is true for Murgatroyd’s original as well as for the later ‘A’ and ‘B’ types. It’s in deep trouble, for the trouble is deep-down. Although in its standard form the Bush Pump uses well-proven and durable ‘down-the-hole’ components, some of these eventually need to be replaced. For instance, the leather seal may wear out, a common cause of pump failure. Rods may separate, and various things may go wrong with the footvalve, the piston and the rising main.³⁹ If they break down, then they need to be repaired or replaced. But how to get them out?

In the standard model, the diameter of the cylinder (the part that holds the hydraulic components, the piston and its seals, shown in Figure 5) is greater than that of the rising main. And since it is at the bottom of the main, its components cannot be pulled out. In order to repair damage to valves or seals (located in the cylinder and sized so that they fit tightly), the piston needs to be pulled to the surface. This means that the pump’s (heavy) pipes and rods also need to be raised, that the pump must be taken apart, perhaps that the apron will be damaged. And since – unlike its installation – taking a pump apart to repair it demands a skilled team, this means that the pump may stop working and fail to provide water if no skilled team is around.

In the latest version of the ‘B’ type – not yet standard, but maybe becoming so after the prototypes have been thoroughly tested – the situation is different. When its hydraulics break down they can be mended. For this new pump has ‘down-the-hole’ parts that may be *extracted*. Its

FIGURE 5
Cylinders

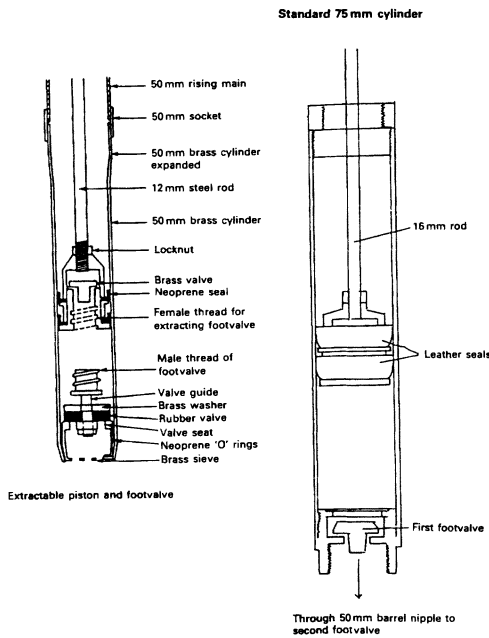

Source: [Morgan, 164].

cylinder is 50mm in diameter, with a 50mm piston, and the rising main is reamed out just a little more than in the standard model. The piston still fits tightly in the cylinder, but – because the rising main is larger in diameter – is now narrow enough to slide through the rising main. In addition, the footvalve and the piston valve are inversely threaded, so that they can be screwed together; the footvalve can then be pulled up as well.⁴⁰ This version of the pump uses lighter 12mm rods instead of the 16mm ones, and the rods are held together with eyes and hooks rather than threaded joints, so as to make it easier to take them apart. As a result of these adjustments it is possible, even fairly easy, to take out the moving parts. And they can be removed without taking the entire pump apart; without destroying the headworks and possibly damaging the well. In this way the parts can either be repaired or be replaced – and this can be done locally.

It is anticipated that the replacement of seals will be undertaken by Pump Caretakers or Pump Minders with the assistance of the community who use the pump. Community assisted maintenance of this type is desirable as this reduces the burden on the DDF [District Development Fund] and also involves the community more in a simple and understandable procedure which can be undertaken with minimum risk.⁴¹

Whereas the design of the down-the-hole parts still looks rather complicated to the non-specialist, working on them sounds surprisingly easy. Two

simple spanners and a few good men, that is all that is needed for routine replacement of the seal. So as to make the 'B' type easier to repair, some of the hydraulic parts can be altered. If 16mm rods are too heavy to be easily taken apart, 12mm rods may take their place. If disconnecting threaded rods is too hard, hook-and-eye connections will serve. And if a 75mm cylinder's piston can't pass through the 50mm rising main, the cylinder may be reduced in size and the main slightly expanded. If something is lost in all this – a 50mm cylinder lifts less per stroke than a 75mm cylinder, and a 12mm rod is not as versatile as its more sturdy 16mm friend – then something is gained: *reparability*. And if this advances long-term performance, then the trade-off is beneficial. The pump emerges perhaps less solid, but certainly more viscous: its elements are less rigidly linked. And for long-term performance, such fluidity may be just what it needs.

Mechanics: Nuts and Bolts

One of the attractive features of the Zimbabwe Bush Pump 'B' type is that since it is locally produced, spare parts are easy to come by. This erodes the boundary between pumps in working order and those that are broken, for it helps to turn 'being broken' from a final *state* into an intermediate *stage*. But sometimes spare parts aren't even necessary. The pump proves to be adaptable in unexpected ways. Thus, though the seal is normally leather, if a spare leather seal is not available a properly-cut section from an old tyre may do just as well (though it doesn't last quite as long).

And consider the following – a more dramatic alteration in the above-ground section of the pump. As we have seen, this section comes in three pieces: a base, a pump head and a lever. Each of these pieces is fixed with heavy bolts. The manuals and descriptions sternly advise that these bolts be tightened from time to time: 'Keep all these bolts tight with a spanner' is the maintenance instruction that, like the spanners themselves, comes with the pump (see Figure 6).⁴²

Since users get wary of bolts coming loose, and since Pump Minders lose spanners, bolts have been devised that don't need to be tightened so often.

The wooden block [that acts as a lever] . . . is supported by a large head bolt. In the older standard pumps, the wooden block rotated around a length of 25mm steel pipe (pivot tube), which was clamped within the [steel] plates [welded to the pump stand] by the nut and bolt. In the latest standard pump, this is a 35mm diameter solid steel bolt equipped with a squared head, to avoid rotation. The bolt is manufactured with a shoulder and spring washer system which keeps it tight. Earlier head bolt systems, which were fitted with a lock nut system, had a tendency to come loose. [Morgan, 160]

These bolts, then, take over the jobs of Pump Minders and Caretakers and add to the endurance of the pump in yet another way.

However, further inspection suggests that tightening the bolts or providing bolts that do not come apart may not be that important after all.

FIGURE 6
Tools and Spares, as Pictured in Instruction Manual

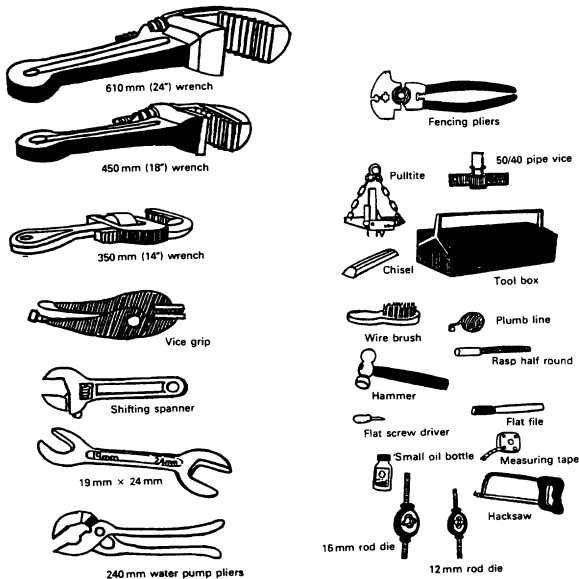
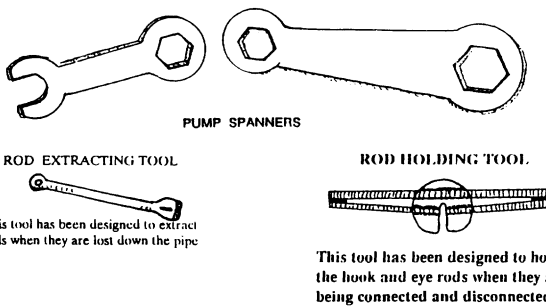

Fig. 6 'The Right Tools for the Job' (Morgan 1990, 181; 1994)



Source: [Morgan, 181]; Morgan, op. cit. note 12, 9.

It appears that the device may do (for a while, at least) without many of its bolts and still not lose its ability to pump. Of the 'B' type, the new model that became standard in 1989, Morgan writes fondly: 'It is a very forgiving pump, and is able to endure much punishment yet will still perform when many parts are badly worn out' [Morgan, 154]. And talking about the pump he recollects:

Visiting the pumps, I have been amazed at how well they function without some of their parts. I have seen pumps that have lost all the bolts that tie the base to the body. Apparently the body is heavy enough to be locked in place even without the bolts. But when I was touring some of the pumps with a Swiss visitor last week, I was amazed to see a pump that had no bolts left in the lever. In order to attach the block to the lever they had

stuck steel bars through the holes. Now *that's* what I call resilient technology and ingenious adaptation.³

The people in this village ingeniously adapted the pump. So while the design shifts, making the Bush Pump ever more repairable, its hydraulic elements easier to replace, its mechanical components better adjusted to their tasks, the extent to which the device can be repaired may surprise even the adapting inventor. With amazement he notes that some bolts need not be replaced by original spare parts at all. Steel bars can do the job.

Hygienics: Standards Revisited

So mechanics and hydraulics may be tinkered with to a considerable extent before the pump stops lifting water. But is this also true for hygienics? In discussing this we will shift away from the adaptability of the pump itself, to consider what it means for it to *work*. A pump works as a provider of water if water comes out of it when the pump handle is properly operated. But how to determine whether or not a pump is a successful technology for health?

We have already considered this question, so it may seem naïve to ask it again. We said that there are quality standards for water, *international* standards. According to the International Reference Centre for Community Water Supply and Sanitation (IRCCWSS) in The Hague, the levels of *Coliform* present in acceptable drinking water should be less than 10 per 100ml sample; and the number of *E.coli* less than 2.5 per 100ml [Morgan, 249]. The norms are clear: they distinguish clean water from water which is contaminated. They can be used to determine whether or not a specific pump acts as a health-promoting technology: simply do a *Coliform* and an *E.coli* count of the water it pumps up, and compare these with the standards.

However, in Zimbabwean rural areas there are a number of reasons why this is not so easy after all. To begin with, it may be fairly difficult to organize the measurements required in vast, 'peripheral' rural settings. It requires someone to take the appropriate water samples and do a *Coliform* or an *E.coli* count that has little 'noise', and may be seriously compared to the counts found in the rich, well-equipped and well-staffed Dutch laboratories in The Hague. Nevertheless, the Blair Institute musters its resources and does such measurements all the time. But, and this is the follow-up point, despite all these efforts the numbers only tell us about that moment in time. Over, say, a whole year, the pump's performance may be better or worse. For in the rainy season, when the soil is soaked with water and bacteria thrive, the situation is likely to be quite different from that in the dry season, when the arid soil enables far fewer species to survive.

What does this mean: that it is impossible to say whether a pump provides health or whether it fails? That the Blair Institute should stop doing these measurements? No, these things can be said and done. But – and this is what we can learn from the Blair Institute in Harare, but *not* from the laboratories in The Hague – such measurements do not achieve

significance by being compared with allegedly universal standards. Instead, there are other, again more fluid, ways of handling them properly.

A first move is to recognize that in the Zimbabwean context questions of health are relative, not absolute. As Morgan argues: ‘The important question is, how meaningful are the standards in practice’ [Morgan, 249]. Health questions don’t have to do with setting standards scientifically, but rather with the practical comparison of alternatives. Thus, even though a protected Bucket Pump well may have an *E.coli* count of 25, it may be sensible to continue using it if the closest alternative is a shallow unprotected well with a count that is ten times higher. Other options, like purifying the well and installing a standard Bush Pump – bound to result in a lower *E.coli* count – may cost too much. And even if it is possible to find the money for a Bush Pump, this may not be better in the long run if the community is too small to maintain the Pump properly.⁴³

Second, though there is no doubt a relation between *E.coli* counts and *health*, it isn’t linear. It is not a direct or a rigid relation; it is fluid. And it depends not only on the *number* of *E.coli*, but also on who(se) they are. For, as we mentioned above, *E.coli* may make us sick when they are foreign, but they are less likely to do so if we are familiar with them. So even if the *E.coli* count of a particular water sample is 25 – ten times the acceptable levels according to the IRCCWSS standards – this does not necessarily mean that the health of the community using the well is critically impaired. If the number of users of the well is relatively small *and* changes little, then the ‘users can more easily harmonise with the well or tubewell itself, including the micro-organisms that may pass to and from the well via the user’ [Morgan, 252].⁴⁴

It is all well and good, then, to determine mean *E.coli* counts from a significant number of samples, taken from a series of pumps at different sites on different dates, so as to compare performances of pump types and measure them against the IRCCWSS standards – but this is not enough to determine whether or not these pumps *work* properly to promote health. For although such surveys provide a lot of information, they do not tell us whether a particular groundwater source is sound. Morgan is very clear on this. Witness the following table of results from the Blair Research Laboratory (Table 2). Taken from Morgan’s prescriptions for appropriate sanitation measures, it exemplifies the way in which he emphasizes the continuous monitoring of local sites, his attention to variability, and his tribute to the significance of the local order of things.

In the end, then, standards like those issued by the IRCCWSS hardly apply in the Zimbabwean context because they not only *create* but also *require* uniformity.⁴⁵ Such standards only make sense if instances can be meaningfully compared. A meaningful comparison between the *E.coli* count of different sources requires them to be more or less uniform in other respects. But in Zimbabwe one water source is *never* quite like any other. The conditions at one well are never the same as those at another. And although they may be the same as they were a week, a month, a year ago, or at the beginning of the season, it is more likely that something will

TABLE 2
Bacteriological Data for Groundwater

Date	Traditional wells										Bucket Pumps										Handpumps										Comment
	W57/	W58/	W59/	W61/	W62/	W63/	W64/	B9/	B10/	B11/	B13/	B16/	B17/	B18/	B19/	B20/	B21/	B23/	W3/	W3/	W3/	W30/	W31/	W34/	W35/	W36/					
9. 1.84	65	140	550	350	1800	1600	1800	0	2	0	35	0	0	25	2	-	-	-	8	2	2	0	0	0	0	-					
16. 1.84	50	250	250	350	550	350	1800	8	225	2	0	0	0	9	550	-	-	-	275	7	45	0	7	17	-						
25. 1.84	20	25	550	1600	1800	25	225	0	5	0	0	0	2	0	7	-	-	-	5	20	0	0	0	0	-						
30. 1.84	1600	425	170	900	1800	95	35	25	70	0	4	0	110	2	-	-	-	-	5	0	0	0	7	2	-						
13. 2.84	35	110	225	95	1800	170	40	11	50	2	0	5	0	2	-	-	-	-	8	8	0	0	11	0	0						
20. 2.84	250	17	20	250	1600	900	350	0	0	2	0	2	0	2	0	5	-	-	5	0	0	17	0	0	0						
28. 2.84	50	1800	95	45	250	225	1600	0	0	0	0	2	0	5	2	0	-	-	13	0	0	0	0	5	2						
5. 3.84	130	550	80	80	350	550	80	0	0	5	14	8	0	7	2	5	-	-	5	14	0	2	2	0	0						
12. 3.84	330	350	550	550	1600	350	350	0	7	5	0	0	17	14	11	0	-	-	5	14	0	0	0	2	0						
20. 3.84	250	40	425	550	1600	250	1600	11	35	11	0	0	7	17	5	5	-	-	5	50	0	0	0	0	0						
26. 3.84	1600	17	250	550	225	170	120	0	11	8	0	2	0	2	2	0	0	-	2	0	2	0	0	0	0						
2. 4.84	550	1600	250	900	95	1800	1800	0	1600	2	5	2	2	5	350	2	350	-	250	5	5	2	9	11	0						
9. 4.84	225	35	14	40	140	1800	1800	0	4	0	4	2	5	0	7	2	0	14	-	2	2	0	DRY	2	5						
24. 4.84	50	2	6	7	11	50	80	0	0	4	4	2	4	2	17	0	0	-	5	0	0	-	0	2	0						
7. 5.84	170	8	40	1800	5	35	50	5	0	11	8	5	2	4	6	0	0	-	0	0	0	0	0	2	0						
14. 5.84	57	13	50	110	550	80	900	2	-	35	0	0	0	5	0	0	2	-	2	0	13	-	0	5	2						
11. 6.84	110	7	31	550	1800	14	140	0	0	9	8	2	0	0	DRY	-	0	-	0	0	0	0	-	0	2						
6. 8.84	2	0	5	0	0	0	DRY	0	0	0	0	-	2	0	0	0	0	-	0	0	0	-	0	0	36						
22. 8.84	25	250	25	2	110	70	-	0	0	2	-	0	0	0	-	0	0	-	2	130	0	-	5	0	2						
3. 9.84	2	4	4	4	0	12	-	0	0	2	0	-	0	0	-	0	0	-	7	0	0	-	2	0	0						
24. 9.84	130	14	-	20	17	-	-	0	0	0	0	0	0	0	-	0	0	-	0	0	0	-	0	0	0						
8.10.84	1800	4	25	8	2	32	-	0	0	8	0	2	0	DRY	-	2	-	0	4	0	0	-	0	0	2						
22.10.84	35	14	8	900	35	-	-	0	0	13	0	0	0	-	0	-	0	-	0	0	0	-	8	0	0						
5.11.84	80	17	55	80	50	1800	-	0	5	4	0	0	0	-	17	-	4	-	0	0	0	-	5	0	8						
19.11.84	70	20	110	50	350	1800	-	0	2	0	0	0	0	-	5	0	0	-	5	0	0	-	8	0	2						
3.12.84	1800	70	1800	-	202	350	-	2	50	8	2	2	2	-	5	-	0	-	50	0	13	-	7	8	0						
8. 1.85	350	40	110	1600	1800	900	-	2	0	0	-	0	0	-	2	-	0	-	13	25	2	-	5	2	2						
21. 1.85	1600	1800	1800	1800	-	-	-	8	40	70	35	80	2	-	7	-	2	-	25	17	8	-	110	11	14						
11. 2.85	1800	55	110	35	1800	50	-	0	0	5	2	2	0	-	0	0	-	0	2	0	17	-	5	5	-						
25. 2.85	350	11	275	20	225	130	-	4	0	5	0	0	0	-	2	-	0	-	2	0	2	-	0	0	25						
11. 3.85	1800	35	550	170	1600	130	-	11	11	8	7	8	0	-	-	0	-	13	8	0	0	-	2	0	13						
Total <i>E. coli</i>	93653										4358														1466						
No. samples	197										261														191						
Mean <i>E. coli</i>	475.39										16.69														7.67						

Source: these data were collected from traditional wells and tubewells fitted with Bucket Pumps and Bush Pumps, and analyzed by the Blair laboratory in Harare [Morgan, 77].

have altered. The number of users, their identities, the amount of rainfall, the bacteria – all may have changed significantly. In some Zimbabwean contexts, it may be the identity of the users that is most important in determining whether a pump works or not.

As a promoter of health the Bush Pump thus works in a number of different ways, and with varying degrees of success. The limits to its performance are related to its cost, to the precariousness of its siting, to its construction, to its well-size and depth and to its maintenance. Its very installation may cause it to fail if it changes the local situation in ways that could neither be foreseen, nor easily monitored. So it makes no sense to try to determine whether the Bush Pump provides health in terms of some solid, ‘gold standard’.⁴⁶ There are, indeed, moments – for instance when an entire village suffers from chronic infection due to contaminated water – when it is possible to say that a specific pump failed to provide health. There are others, such as when *E. coli* counts stick to zero for long stretches of time, when the opposite is the case. But a lot is going on between these two extremes. So instead of a binary boundary, we see fluid transitions once again, here.

Community: Villages or Families

The decision to standardize the handpumps in the rural water programme was made by the Zimbabwean Government’s National Action Committee in 1987. Maintenance was a significant factor in this decision. As Morgan says:

[W]ithout maintenance the pumps can fail and [remain out of order for months. It is therefore the maintenance program, rather than the pump itself which determines whether a handpump program will be successful in the long term, assuming, of course, that technical faults in the pump itself have been reduced as far as possible. [Morgan, 67]

But, as we have argued above, the pump and the maintenance programme can hardly be thought of separately from each other – as the pump’s working order depends on the maintenance programme, which in turn depends on a community to keep it up and running. And so the Bush Pump *requires* a community to maintain it if it is to work. Meanwhile, a working pump also *constitutes* its community. It is through development projects such as Zimbabwe’s programme for providing rural water that communities form themselves around a pump; it is through such programmes that they acquire a shape, a size and a materiality that they did not have before. After all, if pumps are to be successfully maintained, some degree of organization and division of responsibility are needed; the community needs to assume joint ownership and so affirm itself *as* a community. And so with a Bush Pump – or any other standard pump – the community acquires a piece of equipment that it subsequently enrolls in its efforts to organize and form itself.

A pump may fail to marshal a community around it. It may prove too weak: in one way or another insufficiently attractive to become a centre. If

this happens, if a pump fails to make the community it needs, then the community will not take care of the pump either. The bolts are not tightened. The spanners disappear. Kids throw stones down the well. The aprons are not kept clean. The pump is not used. All these failures follow from the first: the failure of the community to materialize as a responsible and proprietary body.

It is possible that this puts limits on the size of the target community. For, although the government assumes that the village is the standard unit of organization, the kind of 'community' that keeps up a pump is not pre-given in this way. If it is too small, as we have seen, maintenance is a tall order. But if it is too large, failure is quite likely as well: '... maintenance carried out by the community [like] sweeping aprons and keeping the water run-off clear ... is practical in units owned by a few families, but far less so in heavily used communal units, where there is no sense of ownership' [Morgan, 108].⁴⁷

So what happens if the community-building part of the Bush Pump fails? The answer is that if it fails comprehensively then the pump in question may fall into disrepair. It may stop being used and die. But the pump project and the Bush Pump 'B' type do not necessarily die with it. For with changes in policy, the operation and maintenance of the pump may be shifted to another kind of unit with an alternative kind of responsibility and ownership. The village unit may be replaced by one comprising only a few families. And the pump may be put somewhere else: not in the middle of the village but in one of those families' back yard.⁴⁸ So that rather than an elaborate system of communal responsibility, an alternative arrangement, one of private ownership, takes shape.

[Pump distribution] may be an important factor to the future success of pump maintenance. In several projects, pumps are placed so that each one serves about 5 families (30 persons). This arrangement ties in with the extended family system in Zimbabwe. The families using a single installation are closely related and may already be accustomed to using their property collectively and sharing financial responsibilities. It is very possible that the distribution of pumps to suit the extended family system may be very crucial for successful village level maintenance. [Morgan, 107]

Then does the Zimbabwe Bush Pump work? It may – but perhaps enabling it to work dependably requires some modification of the government programme for improving rural water supplies. For aiming at extended families rather than villages means a shift from boring new wells and installing Bush Pumps to upgrading existing wells – and in some cases choosing other water-lifting devices like the Bucket Pump.⁴⁹ It fragments the terrain more unevenly, making the local even more local than it was when the village was the organizing unit of choice. Such a change might make rural Zimbabwe look different, made up of units that are different from those the government has been seeking to reinforce. No wonder that an article headed 'Now in My Backyard – Zimbabwe's Upgraded Family

Well Programme' reports that the 'well programme is a hit with the people but goes against the government grain'.⁵⁰

Standardization: Keeping Up the Supply

Even if smaller units emerge in the course of Zimbabwe's rural water supply project, that does not mean that the Zimbabwe Bush Pump 'B' type is not a national standard. The Bush Pump may to some extent have to share the territory with upgraded wells and other pumps, but it is still the preferred national water device – that is, if the manufacture of its hydraulic elements and other parts continues. The success of the national standard, after all, depends on the local manufacture of new pumps and spare parts. If this were to fail, villages with a pump wouldn't be in too much trouble for the time being – until they need spare parts, that is – but the nation that needs pumps for newly-bored wells would have a problem indeed.⁵¹

Spokespeople in Zimbabwe pointed out to us that the continuation of its manufacture has been a fragile element in the working of the Zimbabwe Bush Pump 'B' type. For a long time it seemed as if it might be its *most* fragile element – and if this was the case, then it was precisely because it is the least fluid. Until recently, both Bush Pump and Bucket Pump were produced in a single plant, run by a single person whose engineering expertise, rigorous quality standards, authority and enthusiasm for appropriate technology formed the fiercely idiosyncratic mix on which its manufacture relied. An equally committed person who might take over did not seem to be around. So it was a matter of genuine concern how long V&W Engineering would be able to manufacture the two standard high-quality pumps; that the nation's water infrastructure, the arbiter of life, illness and death for so many, itself depended on the life, illness and death of that single figure, the engineer-director of the pump-producing plant. However, the manufacture of the pump is at present no longer under threat – because its manufacture has been decentralized. The design and process of manufacture are now shared with other producers.

The Bush Pump is now made well by at least 6 companies and moderately well by another 6 companies. . . . This has been encouraged by UNICEF. . . . The threat . . . that quality manufacture could not be assured in the future has now been overcome.^b

A Fluid Outcome

It is not easy to assess the successes and the failures of the Zimbabwe Bush Pump 'B' type. For if the pump must act, what is it to do: provide water or provide health? Build communities or make a nation? And when does it succeed in doing any of these? The criteria for success are not clear-cut. So the Zimbabwe Bush Pump not only has fluid boundaries, but the evaluation of its activities is fluid, too. While some of its parts are essential, many can be replaced with something else. Even if many of its elements are transformed, 'the whole' does not necessarily fall apart. And the standards that seem ready to be applied to it may stop making sense, or change.

There are, to be sure, limits to the Bush Pump's flexibility and elasticity. There are points where nothing works, everything fails. But before such dead ends are reached – *if* they are reached at all – many varied things may happen to a Zimbabwe Bush Pump. As indeed they do.

The Place of the Maker: The Centre of the Zimbabwe Bush Pump Distributed

... no individual has total command over it. It is in the public domain.^a

We have argued that the Zimbabwe Bush Pump is a fluid actor. It brings a lot about, but its boundaries and constitution vary and its success and failure, instead of being clear-cut, are a matter of degree. Although one knows a Zimbabwe Bush Pump 'B' type when one sees it, we claim that the technology has no core. Or has it? For a long time there has been, we have mentioned him, a single stronghold in its manufacturing: the engineer-director of V&W Engineering, the plant where the Bush Pump is produced. 'Without Mr Von Elling, the Pump would not be this good ... its future uncertain', Peter Morgan insists.^a However, with the distributed manufacture of the pump, Von Elling's rôle is no longer central to it. And even before such distribution, Von Elling told us another story. When questioned then, he acknowledged that the pump depends on a combination of his and Morgan's individual strengths. But he added a little later: 'The pump is really Dr Morgan's invention. It is his thing. We just manufacture it'.^c

The pump's possibilities for acting may depend on another actor who brings it into being. It *may* be his thing. But whose thing, exactly? For a long time Von Elling was the centre of the Bush Pump's production. Its *manufacture* depended on him. But what about the *development* of the pump? What about the inventions that shape, reshape and gradually improve the pump? Is Von Elling right that these activities, so crucial to the 'B' type, all depend on Morgan? Morgan's centrality is a moot point – he turns out to be an interesting actor because he doesn't assume that he is one. Instead, he manages his own dissolution. This partly explains the Bush Pump's attractiveness, and perhaps some of its dissemination as well: the fact that there is a fluid hero behind it.

Authorship–Ownership

Dr Peter Morgan started his African career as a microbiologist in Malawi, doing fundamental research on the bilharzia cycle. One of his papers led to an invitation by the Zimbabwean (then Rhodesian) Ministry of Health to come to Harare and do research there for a few years. So it was a government official who initiated this move to Harare – not Morgan himself. He stayed in Zimbabwe, but he did not stay in basic science. Asked why, he doesn't mention a particular decision. Instead, he cites an American colleague who, early on, challenged him on his engagement in a rather esoteric study of one of the many parasites threatening the health of

Africa's rural population. Didn't improving rural health really depend on water sanitation? Taken by the suggestion, Morgan became a government scientist involved with Zimbabwe's water sanitation programme. His colleague's challenge made him shift his attention from bilharzia to the Bush Pump and various other technologies intended to improve water infrastructure.

Dr Morgan has invested much work and effort in improving the Bush Pump. But he has never claimed authorship.⁵² He refuses to take out a patent on the Pump, or on any of its recent modifications, although, according to officers of the African Regional Industrial Patent Organization in Harare, the 'B' type might have been eligible for exclusive property rights.^c But in Morgan's eyes the current pump is no more than a perfected version of a long-established and locally-developed technology that has always been part of, and belongs in, the public domain. It is not the product of the eyes, the hands and the brain of a single man, but a result of collective action and of evolution over time. Morgan knows that the Pump is good, but he insists that this is not because he made it well but because he had great materials, just the expertise that was needed, and dedicated people to work with.

So according to Morgan the pump is no more his than it is Murgatroyd's, Von Elling's or the Pump Minders' who substitute sticks for bolts.^a A comparison with Louis Pasteur (in Bruno Latour's version) is striking.⁵³ Their displacements are rather similar: Morgan moved from Malawi to Zimbabwe, from bilharzia to Bush Pump, from fundamental science to pragmatic technologies, in much the same way that Pasteur moved from crystallography to bacteriology, from Petri dishes to cows, and from the secluded Paris laboratory to the Neuilly farm crowded with journalists. But while Pasteur skilfully hid the activities of all the other actors making up the vaccination network to emerge as its prime mover, Morgan never stresses the possible brilliance of his insights or the ingenious character of what he has invented. Instead, he presents them as matter-of-fact, collective and mundane. And he insists that it is the combination of external inspiration, fortunate coincidence and collaborative effort that makes the difference between a good technology and one that doesn't work.

The rejection of the role of master-mind may be read as an expression of Morgan's modesty. And so it is. But something else is going on, too: granting the pump's ownership to 'the people' contributes to its success. Because when the users – be it actual users, donors or governments – pay for the pump, they pay for materials and production costs. But they do not pay for the right to use it. And they do not pay for a name, for legal and maintenance fees, for the overhead of patent institutions, or for the inventor's retirement pension. Since such costs are not included in the price of the pump, the people have access to an affordable technology. And in the Zimbabwean context this greatly helps the Bush Pump to spread.⁵⁴ Morgan, then, seems to dissolve his own actorship, how to say this, *actively*. He *gladly* submerges in the various surroundings of which he and the

pump are part. When asked about the secrets of the pump's success, he stresses that:

The pump is a government thing, developed by a government employee, in government time, at a government agency. There is no patent on it. No names are attached to it. It is the national handpump. That is its strength. That no individual has total command over it. It is in the public domain.^a

Sometimes abandoning control may contribute to spreading what one has been making.

Implementation

The dissolution of the maker goes beyond the invention of the pump: it is a telling feature of its implementation as well. For Morgan is not only busy improving the hydraulics and mechanics of the Bush Pump, but he also helps to implement it. Again, however, he does so not by taking command, but by trying to let go. By allowing for surprises. And such surprises do, in fact, occur – and steer the further development of the pump.

I encounter surprises. For instance, I developed a pump that yields more water per stroke. Initially, when I started to develop the extractable down-the-hole components, I worked with small (50mm) casings and cylinders, that would hold light pipes, in order to make pumping and maintaining as easy as possible. But then you don't get very much water per stroke. So in order to improve the yield per stroke I developed a pump that has a larger cylinder, but that, accordingly, needs heavier pipes. I was worried about this pump because it would make maintenance more difficult, and for me sustainability was the primary target in developing the pump with extractable parts in the first place. So I expected that this new variety would not meet great demand. But now, everyone is ordering the larger pump. Although I may not find it the best way to go. It's not up to me. Sometimes you just cannot tell.^a

Sometimes you just cannot tell. And it may be important to avoid wanting to do so. Take the crucial question as to *where* the well for a new pump must be drilled. Zimbabwe has a Research Institute for Remote Sensing and Environmental Science in Harare that might seem perfectly suited to answer this question, for here GIS surveys are carried out and satellite maps compiled. But the institute does not determine the constitution of the nation's developing water network. Although nicely coloured schemes faithfully map how much water is to be found where, and expensive satellite pictures painstakingly identify its sources – from reservoirs to aquifers to individual wells – this knowledge from the capital centre is not enough to build a water infrastructure in the rural periphery.

Instead, the map and the GIS survey, as well as the civil engineer employed by the NGO, and Peter Morgan for that matter, are made small and turned into 'mere' facilitators. They are turned into what, with a telling reversal, we might call 'peripheral agents'. The true centre is elsewhere, and it comes in great numbers. It is in the well-to-be-made and in its

prospective users. It is at the village level, where rationales and arguments that come from the capital are added to the advice of the *nganga* about which sites might be best for a well. Does the map show a few spots in the village where water might be expected? Does the manual say that a good distance from the cattle kraal must be respected? Fine. Those messages travel on paper along with the experts, and people listen to them. But the *nganga* must speak before the rig is set up and installation of the pump begins.^{d, f}

Morgan, as a promoter of *distributed action*, insists on this. He is firm about the necessity of abandoning control. Implementation, he maintains, depends on involving those who will use the pump. It therefore requires room for their methods and insights. Without this, any pump is bound to fail. For, as he says, in water development it is all too common that the new and the foreign does not work, and that ‘all that glitters . . . end[s] up as a rusty heap of useless technology’.⁵⁵

Monitoring

Sometimes Morgan goes back to visit the sites of his water pumps. But when he does so he does not carry a bag of nuts and bolts. He is not intent on keeping the pumps as they were delivered: intact, in shape, shining like new. Instead, he tries to learn from the way the pumps have evolved on-site, from the ways in which users have repaired and adapted their devices. Instead of striving to keep the pumps as they were, he is curious to see what they have become. So once a pump is out there, it is out there and it will have to do without any further unsolicited intervention.⁵⁶

Morgan likes to see what has become of his pumps – he likes to be surprised. But going out to check on Bush Pumps is not something he does regularly; it is not an element of a strategically designed system of monitoring. It is, rather, something that happens fairly erratically, incidentally. It is mainly to give others a chance to learn about the Bush Pump in its village environment that Morgan goes out to visit at all. So it can happen that what he learns about the pumps is a result of his efforts to teach others. Still surprised, it seems, he says: ‘If it hadn’t been for my Swiss visitor, I would not know now that the pump can even work without those bolts in the lever – that I had thought, so far, to be the really crucial ones’.^a

Morgan, then, is driving the Bush Pump precisely because he is not central to it. However, not being an *actor* does not mean that Morgan is turned into someone who is *passive*. He puts a lot of effort into dissolving – believing that it is precisely this which creates pumps that yield water and health in their Zimbabwean sites. So what should we call what happens here? Morgan creates a non-creator subject, a dissolved self – not so that he will fade away, but in order to get clean water flowing everywhere. Perhaps all this is so appealing to us because it is so far removed from the control-drive of the modern subject – and even further from the shape this subject takes in generals, conquerors and other exemplars of strong and solid

authority. Serving the people, abandoning control, listening to *ngangas*, going out to watch and see what has happened to your pump: this is not the line taken by a sovereign master.⁵⁷ Here we have, instead, a feminist dream of an ideal man.⁵⁸

To Conclude

The Zimbabwe Bush Pump is easy to love.⁵⁹ Not only because it provides access to clear water for many people in rural Zimbabwe – which is certainly a good thing. But also because, in the way it does so, it teaches us something crucial about the kind of actorship that technologies may take upon themselves. They may be both modern – providing equally clean water in many places – and non-modern – adapting to very different rural Zimbabwean villages. In this paper we have related various aspects of this actorship by using a single term: the notion of the *fluid*. The Zimbabwe Bush Pump is fluid. We have tried to sketch what in the title we call, with a smile, the *mechanics* of this fluid technology.

The first aspect of the Pump's fluidity is that its boundaries are not solid and sharp. The Pump is a mechanical object, it is a hydraulic system, but it is also a device installed by the community, a health promoter and a nation-building apparatus. It has each of these identities – and each comes with its own different boundaries. To write about the Bush Pump in this fashion means that we do not mobilize the arid trope of describing a small technological artefact as if it were surrounded by large social environments – to which it inevitably remains alien.⁶⁰ In each of its identities the Bush Pump contains a *variant* of its environment.⁶¹ This also more sharply frames the question about whether or not the Bush Pump succeeds in its activities, since this is different for each of its identities.

The second, related aspect of the Bush Pump's fluidity is that whether or not its activities are successful is not a binary matter. There are many more relevant answers to this question than a simple 'yes' or 'no'. The Pump may work as a water provider and yet not bring health. It may work for extended families but fail as a connecting element in larger communities. It may provide health in the dry season but not in the rainy season. It may work for a while and then break down. Good technologies, or so we submit after our encounter with the Bush Pump, may well be those which incorporate the possibility of their own break-down, which have the flexibility to deploy alternative components, and which continue to work to some extent even if some bolt falls out or the user community changes.⁶²

And then there is the actor behind the Pump, who refuses to act as such. Dr Morgan's carefully sought dissolution, his deliberate abandonment, is not simply an asset in any man, but is especially suited to the dissemination of the Bush Pump. Pleased with what he calls the 'forgiving nature' of the Bush Pump, he has made it after his own image – infused it with a fluidity that he incorporates himself as well. It may be that to shape, reshape and implement fluid technologies, a specific kind of people is

required: non-modern subjects, willing to serve and observe, able to listen, not seeking control, but rather daring to give themselves over to circumstances.

This, then, is what we have to add to the collective effort of updating traditional notions of the *actor*. Our actor, the Bush Pump, goes to show, once again, that actors do not have to be humans. And its story tells us that actors, technologies as well as the engineers involved with them, may be fluid – for the better. Now – as an addendum, but not an afterthought! – we would like briefly to attend to the normativity incorporated in what we have just written.

In our tales of the Zimbabwe Bush Pump we have marshalled different kinds of *good*. Some of these have a background in political ways of reasoning – for instance, when we say that it is ‘good’ if water is distributed equally among a people. Others belong within a tradition of ethics, like saying that it is a virtue of the Bush Pump that it treats villagers with respect for their specificities. Yet others are aesthetic: the pump’s parsimony, its beautiful blue colour, its ingenious hydraulics.

But beware. None of these *goods*, or so it seems to us, is universally valid. They are *goods* in, of and to the Zimbabwe Bush Pump. And so it is with *fluidity*. We suggest that the possibility that ‘fluidity’ is a ‘good’ should be considered in other cases, especially in cases of technologies transferred to, or designed for, so-called intractable places. But we do not want to set up *fluidity* as a new standard to replace, or necessarily to supplement, others – for instance, ‘sturdiness’. It *may* be a good – and we suggest that you find out for yourself whether or not it *is* in the cases that *you* happen to deal with.⁶³

This is a matter of normative style. What kinds of relations to the good might one want to establish? Keeping a *neutralizing* distance from it may be helpful in opening up fields that have been occupied by set moralities for too long – but once such fields are indeed opened up, the risk is that neutrality becomes sterile. It brings nothing new, but leads instead to all-too-predictable stories.⁶⁴ In the *critical* tradition, scholars approve or disapprove of technologies, people, situations, arguments. This makes sense if there are clear-cut *points of contrast* from which to judge. But this isn’t always the case.⁶⁵ In our story, it is most certainly not the case; for we have not offered you any other pump stories to compare, nor have we listed criteria that good pumps should always meet. How to be normative when there is no single, self-evident standpoint to speak from? That is what we would like to learn. So we do not seek to put ourselves in a position of *judging* the Zimbabwe Bush Pump. It is, from where we stand, not possible to say whether or not it is unequivocally *better* than its siblings and competitors – or even, for which sites and situations it might be so. Rather, by using notions such as *love*, we want to signal how we are interpellated by it.⁶⁶ So maybe this is an exercise in praise after all. For we never set out to pass judgement on the Zimbabwe Bush Pump, but have allowed ourselves to be *moved* by it. And this paper is an attempt to move you, reader, too.

Appendix: Installing the 'B' type Bush Pump Step-by-Step

- Stage 1 Leave 500mm of the 150mm-diameter steel casing above ground level in a bore hole.
Leave 400mm of the 150mm-diameter steel casing above slab level in a well.
- Stage 2 Fit pump stand to the casing.
- Stage 3 Thoroughly clean the footvalve.
- Stage 4 Connect the footvalve to the cylinder.
- Stage 5 Clean all the 3-metre lengths of 50mm GI pipes.
- Stage 6 Connect the cylinder to the lowest pipe.
- Stage 7 Lower cylinder and footvalve and first length of pipe and clamp.
- Stage 8 Lower all pipes. Always use plumber paste at joints.
- Stage 9 Connect the final length of pipe. Lower the pipe and connect the water discharge unit of the pump head.
- Stage 10 Bolt the water discharge unit in place.
- Stage 11 Check piston assembly. The rod is securely screwed into the piston and held in place with a brass pin. Check that the rubber poppet valve is free to move. Check the rubber seal. This must be fitted with the seal lip facing upwards. If the seal is worn or damaged replace it with a new one. Use a small screwdriver to remove and replace the seal.
- Stage 12 Lower the piston and first pump rod down through the rising main.
- Stage 13 Take the second rod and pass its hook through the eye of the lower rod. Continue to lower rods one by one. When the rods become too heavy to support, use a rod clamp. Lower all the rods until the piston rests on the footvalve. Where full lengths of pipe are used, one extra rod is required to make the final length.
- Stage 14 Mark the rod at the place shown by the arrow in this diagram. Pull up the rod and cut off straight at this mark.
- Stage 15 Thread the rod with a 16mm die. The thread should be 50mm long. To avoid cuttings down the pipe, fit a rag around the rod on the pump discharge assembly.
- Stage 16 Assemble the floating washer housing and washers as shown, so that the lower floating washer lies inside the housing and the upper washer lies above the housing. Add rubber buffer and U-bracket. Tighten rod lock nut on U-bracket.
- Stage 17 Bolt the floating washer housing together. Note: [these] illustrations show the pump being fitted before the apron and water run-off have been made. However, it is normally essential to finish the headworks before the pump is fitted.
- Stage 18 Position the wooden block and the two large head bolts after applying a thin layer of grease to each. Tighten the nuts of each bolt against the spring washers.
- Stage 19 Attach the steel handle and tighten the handle U-bolts.
- Stage 20 Test the pump.

Source: compiled and adapted from Morgan, op. cit. note 12.

Work Frequently Cited

Morgan Peter Morgan, *Rural Water Supplies and Sanitation* (London: Macmillan, 1990).

Interviews and Correspondence

We have used information from interviews and correspondence (see note 1, below). In referencing passages which draw from these sources, we use the following alphabetic code:-

- a Peter Morgan, interview (Harare, 30 June 1997).
- b Peter Morgan, letter to authors (28 March 1998).
- c Erwin Von Elling, interview (Harare, 19 June 1997).
- d UNICEF Zimbabwe, interviews with technical experts (Harare, June 1995).

- e African Regional Industrial Property Organization (ARIPO), interviews with officers (Harare, June 1997).
- f Zimbabwean Scientific and Industrial Research and Development Centre (SIRDC), Department of Remote Sensing and Environment, interviews (Harare, June 1997).

Notes

We warmly thank those we spoke with in Zimbabwe: Dr Morgan, Mr Von Elling, the scientists and managers at SIRDC (the Zimbabwe Scientific and Industrial Research and Development Centre), Unicom workers, and the director and patent experts at ARIPO (the African Regional Industrial Property Organization) – who all gave us their time and their stories, and who welcomed Marianne de Laet so courteously into their worlds of inventions and patents. We also thank the Netherlands Organization for Scientific Research, that provides Marianne de Laet with a research grant for studying the travel of patents, and Annemarie Mol with a research grant for studying the normativity incorporated in technologies. Lucy Suchman and three anonymous reviewers for *Social Studies of Science* were most helpful in sharpening our argument. And finally we thank John Law: he was inspiring, encouraging and critical. And he corrected our English.

1. The materials for this paper come from interviews with health workers, patent experts and pump makers in Zimbabwe; from manuals and handbooks; and from visits to the pump factory and government scientific research institutes. Some quotations are from notes, others from transcriptions. Since we are not engaging in a rhetorical analysis, we thought it justified to leave out the repetitions, pauses and interjections that are characteristic of speech; in view of readability we have, here and there, abridged the words of our spokespersons and streamlined them into ‘writing’ language. Also, we want to make it clear from the outset that we mobilize empirical materials so as to make a set of theoretical points. This paper, then, is not intended to provide an ethnography of the use of water and water resources in Zimbabwe, nor does it offer a comparative evaluation of handwaterpumps in general. Detailing the trials and tribulations of *one particular* handwaterpump’s gestation, policies and use, it aspires to add to the literature on appropriate water devices, but it by no means captures or covers this body of work. For a brief introduction to the problems surrounding groundwater and its use, see the ‘UNICEF information papers on groundwater’ (<http://www.unicef.org/wwd98/index.htm/>); also the FAO series on Land and Water Development, its Water and Land Bulletins, and its Water Reports; and ‘Who Gets the Last Rural Resource? The Potential and Challenge of Lift Irrigation for the Rural Poor’, *IDS Discussion Paper No. 156* (Brighton: Institute of Development Studies, University of Sussex, 1980). For work on other pumps see, for instance Peter Fraenkel, ‘Water Lifting Devices’, *FAO Irrigation and Drainage Paper No. 43* (Rome: FAO, 1986), or our protagonist’s comprehensive analysis: Peter Morgan, *Rural Water Supplies and Sanitation* (London: Macmillan, 1990), which we will refer to throughout the text as ‘[Morgan]’. Much of the literature on water, irrigation and pumps is about South-East Asia; see, for instance, Stephen Biggs, Chris Edwards and Jon Griffiths, *Irrigation in Bangladesh* (Brighton: Institute of Development Studies, University of Sussex, 1978), on hand-pump use in the Indian sub-continent. For an analysis of groundwater problems in (West) Africa, that presents an anthropological analysis of the network configured around the technology, see Harro Maat and P.P. Mollinga, ‘Water bij de uien’, *Kennis en Methode*, XVIII (1994), Vol. 1, 40–63.
2. Unwilling to reduce flexibility to interpretation, we situate ourselves in the semiotic tradition in science and technology studies. For this specific semiotic’s departure from matters of meaning see, for example, Annemarie Mol and Jessica Mesman, ‘Neonatal Food and the Politics of Theory: Some Questions of Method’, *Social Studies of Science*, Vol. 26, No. 2 (May 1996), 419–44. For a powerful critique of the perspectivalism that comes with foregrounding ‘interpretation’, see Marilyn Strathern, *After Nature: English Kinship in the Twentieth Century* (Cambridge: Cambridge University Press, 1992).

3. There is a difference between a hero in the sense of the foreground figure in a drama, where foregrounding is the *author's* choice, and the trope of heroic actorship, where this figure *assumes* that (and acts as though) its actions present all the agency in the play. Our hero is of the former kind; a hero by way of foregrounding and by abandoning agency, rather than by assuming it. We agree with John Law who, in *Organizing Modernity* (Oxford: Blackwell, 1994) and other work, takes to task conventional technology studies for all too easily marshalling the heroic agent as a bottom-line mover in, for instance, innovation and socio-technical change. For the notion of agency through abandonment see also Emilie Gomart and Antoine Hennion, 'A Sociology of Attachment: Music Amateurs, Drug Users', in John Law and John Hassard (eds), *Actor Network Theory and After* (Oxford: Blackwell, 1999), 220–47. Note also that our remarks about our hero are not 'personal': they centre around his actions – we do not venture to say anything about his intentions, his motivations or his personality. For modest action can be emulated; a modest personality cannot.
4. See, respectively, Madeleine Akrich, 'La construction d'un système socio-technique. Esquisse pour une anthropologie des techniques', *Anthropologie et Sociétés*, Vol. 13, No. 2 (1989), 31–54; Akrich, 'Essay of Techno-Sociology: A Gasogene in Costa Rica', in Pierre Lemonnier (ed.), *Technological Choices* (London & New York: Routledge, 1994), 289–337; Akrich, 'The De-Scriptio[n] of Technical Objects', in Wiebe Bijker and John Law (eds), *Shaping Technology/Building Society* (Cambridge: MIT Press, 1992), 205–24. For work on technology transfer the journal *Technology and Culture* is a wonderful source; John Staudenmaier, in *Technology's Storytellers: Reweaving the Human Fabric* (Cambridge, MA: MIT Press, 1989), provides an overview of publications on that issue during the journal's first 20 years of existence; an anthology edited by Terry Reynolds and Stephen Cutcliffe, *Technology and the West* (Chicago, IL: The University of Chicago Press, 1997), offers a selection of articles on technology transfer published in the journal. The problem of technology transfer goes to the question of the 'nature' of technology: in conventional notions of technology transfer – as the phrase indicates – the nature of the technical object is taken to be stable and fixed, while by stories like ours and Akrich's this very assumption is undermined. Whereas this question has been addressed by historians and sociologists of technology (for a first exploration, see the volume edited by Wiebe Bijker, Thomas Hughes and Trevor Pinch, *The Social Construction of Technological Systems: New Directions in the Sociology and History of Technology* [Cambridge, MA: MIT Press, 1987]), it has, until recently, hardly been an issue in the philosophy of technology, which was rather interested in the impact of technology on society and the ethical questions surrounding such impact: see, for example, Jürgen Habermas, *Technik und Wissenschaft als Ideologie* (Frankfurt: Suhrkamp, 1968); Jacques Ellul, *Le Bluff Technologique* (Paris: Hachette, 1987). Currently – treading in the footsteps of history and sociology of technology but at odds with many of the findings from these fields – philosophers of technology are taking an 'empirical turn' (see Peter Kroes and Antonie Meijers [eds], *Philosophy of Technology: The Empirical Turn*, forthcoming), so as to assess the 'nature of technical objects'. In articulating the fluidity of (at least some) technical objects, we engage a philosophy of technology that runs counter to this analytical quest for a fixed and distinctive nature of technology.
5. For this, see Annemarie Mol and John Law, 'Regions, Networks and Fluids: Anaemia and Social Topology', *Social Studies of Science*, Vol. 24, No. 4 (November 1994), 641–71. As Akrich's stories tell us, in the arena of technology transfer the lesson about fluidity still needs to be learned.
6. We are of course not the first to attempt such an update. Identity has been long theorized in constructivist psychology and ethnomethodological sociology as a situational and flexible range of possibilities, rather than as a fixed and solid whole. And including 'non-humans' in the category of 'actors', to attend to what it is they bring about, has, in Paris, been done since the early 1980s: see, for example, Michel Callon, 'Some Elements of a Sociology of Translation: Domestication of the Scallops and the Fishermen of St Brieuc Bay', in John Law (ed.), *Power, Action, and Belief: A New Sociology of Knowledge?* (London: Routledge & Kegan Paul, 1986), 196–233; Callon,

- 'The Sociology of an Actor-Network: The Case of the Electric Vehicle', in Callon, Law and Arie Rip (eds), *Mapping the Dynamics of Science and Technology* (Basingstoke, Hants.: Macmillan, 1986), 19–34. Whether this was a wise move has subsequently become the focus point of an overheated debate: see Andrew Pickering (ed.), *Science as Practice and Culture* (Chicago, IL: The University of Chicago Press, 1992). Obviously, we build on this French semiotic tradition, in which 'actor' is a technical term for all active entities, rather than a title of honour that may be used for humans alone. By so attributing 'agency' to humans and non-humans alike, the term is stripped of intentionality and the path is cleared for simply tracking people, objects, their interactions, and their effects. Note that in following both the Bush Pump and its maker we focus not on intentions, but on actions, movements and effects.
7. And hence, it is not quite a boundary object. A boundary object, a figure that features in symbolic-interactionist theory, moves between (social) worlds, in which it gets interpreted in different ways. While the object's boundaries remain firm, its 'variability' is due entirely to the different ways in which it gets interpreted in those worlds. Our notion of fluidity serves to flag the way in which object and world are *intertwined*; it points to the flexibility of the pump's definition and the variability of its perimeter, but also to its capacity to shape 'worlds'. One of our reviewers aptly called this emphasis on the object's agency our 'non-humanist (versus the other: humanist) approach'. For the notion of boundary object see, for instance, Geoffrey C. Bowker and Susan Leigh Star, *Sorting Things Out: Classification and its Consequences* (Cambridge, MA: MIT Press, 1999). The theoretical text about 'the actor' that comes closest to the present one is not about technical objects at all, but about drug addicts and musical amateurs. Emilie Gomart and Antoine Hennion mobilize these people so as to challenge traditional notions of the actor in a way that we build on here. The actors concerned act while and through *abandoning* themselves: Gomart & Hennion, op. cit. note 3.
 8. See the exchanges between Bruno Latour and Michel Callon *versus* Harry Collins and Steven Yearley in Pickering (ed.), op. cit. note 6.
 9. The term 'heterogeneous engineer' comes out of the work of John Law: see J. Law, 'Technology and Heterogeneous Engineering: The Case of Portuguese Expansion', in Bijker et al. (eds), op. cit. note 4, 111–34. In his work since, Law has taken a lot of trouble to undermine the managerial undertones, for instance (in Law, *Organizing Modernity*, op. cit. note 3) by making an extensive analysis of what it is to 'manage', and later by re-examining the notion 'heterogeneous': see J. Law, 'Hidden Heterogeneities: The Design of an Aircraft', in Law and Annemarie Mol (eds), *Complexities* (Durham, NC: Duke University Press, forthcoming).
 10. Bruno Latour, *The Pasteurization of France* (Cambridge, MA: Harvard University Press, 1988).
 11. We came across this water pump by chance. One of us (MKdL) is engaged in a research project in which she investigates the travel of *patents* into developing countries. Her research strategy of following patents brought her to Zimbabwe, where spokespersons at the African Regional Industrial Property Organization (ARIPO) pointed out this remarkable technology, the Zimbabwe Bush Pump, which stands out because no patent claims have been filed on it. In this paper we touch upon, but do not explore, this particular feature of the pump. For the way patents and development are explored in this project see, for example, Marianne K. de Laet, 'Intricacies of Technology Transfer: Travel as Mode and Method', *Knowledge and Society*, Vol. 11 (1998), 213–34.
 12. For a description of the seal, see Peter Morgan, *The Zimbabwe Bush Pump: A Manual for the Installation, Dismantling and Maintenance of the 'B' type Bush Pump* (Harare: Mvuramanzi Trust and V&W Engineering, September 1994). In his comments on this paper, Dr Morgan noted that the '40 mm pipe is being phased out and is rarely used. Also 12mm rods are being phased out and 16mm rods are used almost everywhere': letter [b].
 13. Most commonly seen in Zimbabwe, and all tested by the Blair Research Laboratory in Harare, are four pumps, each of which belongs to a different 'family'. These are the

- Bush Pump (a lever action steel-bodied reciprocating pump used in shallow to deep [up to 100 metres] protected wells, whose yield depends on cylinder size but maxes 40 litres per minute); the Blair Pump (a direct action hand-operated reciprocating pump with a PVC body yielding 15–40 litres per minute, used in shallow [up to 12 metres] small-diameter wells only) and the Nsimbi Pump (similar in yield and materials to the Blair Pump, but with lever action); and the Bucket Pump (a bucket-and-windlass pump, yielding 5–10 litres per minute, for use in open, shallow, large-diameter wells). Less common is the Rotary Pump, a fourth family of pumps (using a rotor system this pump distinguishes itself by its low breakdown rate: it may be used for 10 years without servicing). Blair and Nsimbi Pumps are limited in durability and yield and, therefore, in the scope of their use. Many varieties belonging to these four pump families are in use over the world. See [Morgan, 62–68].
14. Dr Morgan pointed out to us that this is not to say that the Bush Pump is *better* than those other pumps: ‘All pumps have their merits . . . I think the Bush Pump is good – but I also respect the work of others’: letter [b]. And, as we argue further on, whether or not a pump is good depends on more than the specifications of the pump alone.
 15. Obviously, the relation between clean water and health is not as straightforward as this sentence makes it seem. Good water is essential to health, but in order for people to be healthy, more than water is involved – for instance personal hygiene, nutritious food, and so forth. Here, we narrow our concerns to the water.
 16. The co-existence of human organisms and their fellow-travelling organisms such as *E.coli* is so durable that one may seriously wonder whether it makes biological sense to separate these organisms out as independent individuals. Maybe, in demarcating the *viable*, human *E.coli* deserves to be *included* rather than *excluded*. For this, and thereby for an extensive discussion of fluid boundaries of living organisms, see Ludwik Fleck’s classic study, *Entstehung und Entwicklung einer wissenschaftlichen Tatsache* (Frankfurt: Suhrkamp, 1980; original 1935), English translation published as *Genesis and Development of a Scientific Fact* (London & Chicago, IL: The University of Chicago Press, 1979).
 17. For comparative data of this study, see Table 2, below.
 18. Another quote illustrates this point: ‘weaknesses in design or construction are revealed most dramatically during rainy spells, when the rain helps to flush surface contaminants back into the well or other water source. The hygienic seal of the water point is a most important feature of a well head and is tested most thoroughly during the rains. It is at this time when contaminants from the surface most commonly find a route and drain back into the underground aquifer’ [Morgan, 18–19].
 19. Peter Morgan and Erwin Von Elling, ‘Bucket Pump Manual for Fieldworkers’ (Harare: Blair Research Laboratory, Zimbabwe Ministry of Health, 1990), 4–10.
 20. *Vonder Rig* (video); further information from a factory visit to V&W Engineering (Harare, 20 June 1997), and interviews [a] and [c].
 21. One of the limits of our material is that we do not know how the village women appreciate pushing an iron crossbar with their men sitting on it. Neither do we know how the pump fits in with the other tools and material objects that the villagers live and work with. For some interesting examples of studies that start, not with material from fluid inventors and industries, but with more classic anthropological ‘village material’, see Mary-Jo Arnoldi, Christraud Geary and Kris Hardin (eds), *African Material Culture* (Bloomington: Indiana University Press, 1996) and, of course, the classical collection by Arjun Appadurai (ed.), *The Social Life of Things* (Cambridge: Cambridge University Press, 1986), as well as Lemonnier (ed.), *op. cit.* note 4.
 22. V&W Engineering, ‘Instructions for Drilling Tubewells with the Vonder Rig’ (Harare: Blair Research Laboratory, 1988), 16.
 23. Reasons for including a *nganga* or a local water diviner in the well-siting process are neither exclusive ‘social’, nor exclusively ‘technical’. The *nganga* is in charge of sacred places and rituals. Not all *nganga* are water diviners, not all water diviners are *nganga*; *nganga* have specialized areas of expertise, varying from history and legal issues, to indigenous medicinal knowledge, to water and its likely sites. Drilling wells without

- consulting a *nganga* would be unwise – not only because when they act as water diviners they know about aquifers, but also because they know about people: ‘Natural springs are often sacred places and . . . controversy [may arise] when these are upgraded or protected without consulting the *nganga* or traditional hierarchy’: letter [b].
24. See also Morgan & Von Elling, op. cit. note 19, 6.
 25. Ibid., 29.
 26. The World Bank, for instance, has in the past few years shifted its focus from providing loans to nation-states, to providing assistance directly to local NGOs. Similarly, UNDP increasingly provides grants to local groups. See, for example, Peter Uvin, ‘Scaling Up the Grassroots and Scaling Down the Summit: The Relations Between Third World NGOs and the UN’, in Thomas Weiss and Leon Gordenker (eds), *NGOs, the UN, and Global Governance* (Boulder, CO: Lynne Rienner Publishers, 1996), 159–76.
 27. The fact that community participation is national policy does not mean that it is actual practice. Morgan comments that the move towards Community Based Maintenance is as yet in its experimental stage, and that ‘we are still on the road to achieving this reality’: letter [b].
 28. The ‘campfire’ project displays a conflict of local interests – some of which affirm themselves as global goods. The project entails an effort to relay some of the responsibility for wildlife conservation (affirmed as a global interest but defined as such in a particular setting) to the inhabitants of rural areas, while relaying profits from wildlife tourism to the villages. In practice, this comes with a ban on the killing of (protected) animals – that often end up damaging crops or threatening the subsistence of the local population. Whereas the ban on killing wildlife and poaching is heavily enforced, the protection of rural areas is taken somewhat lackadaisically. As a result the local population, according to some commentators, gets the rough end of the deal.
 29. See Peter Morgan, Ephraim Chimbunde, Nason Ntakwa and Anthony Waterkey, ‘Now in My Backyard – Zimbabwe’s Upgraded Family Well Programme’, *Waterlines*, Vol. 14, No. 4 (April 1996), 8–11. (*Waterlines* is a publication of the Intermediate Technology Development Group, published in London by Intermediate Technology Publications Ltd.)
 30. That is, it is scarce in certain places in Zimbabwe. Note that Zimbabwe itself can also be framed in many ways; for instance, as a whole (water is scarce there) or as a bundle of local areas (water is scarce in some places in Zimbabwe, but not in others).
 31. Of course the question of whether and how the nation can ever be anything *but* an abstraction is the substance of much debate in post-colonial studies: see, for example, Homi Bhabha (ed.), *Nation and Narration* (New York: Routledge, 1990), and Richard Werbner and Terence Ranger (eds), *Postcolonial Identities in Africa* (London: Zed Books, 1996). On the formation and fragility of nation states in Africa, see Basil Davidson, *Africa in History* (London: Paladin, 1979), or April Gordon and Donald Gordon (eds), *Understanding Contemporary Africa* (Boulder, CO: Lynne Rienner Publishers, 2nd edn, 1996). For a recent analysis of politics–society relations in the ‘Third World’ which pays at least some attention to technology, see Mehran Kamrava, *Politics and Society in the Third World* (London: Routledge, 1993).
 32. Morgan, op. cit. note 12; Peter Morgan, ‘Zimbabwe’s User-Friendly Bush Pump’, *Waterlines*, Vol. 14, No. 2 (October 1995), 23–26. Most current numbers from Morgan, letter [b].
 33. UNICEF has adopted the ‘B’ type not only for use in Zimbabwe, but is beginning to promote its use in other places as well. The pump is used widely in Namibia, and is being tried in South Africa and Swaziland: Morgan, letter [b]. We have not looked into this, but we will not be surprised if the stories of the pump’s boundaries, successes and failures in these other places turn out to be different from the one we tell here.
 34. For a development of the notion of ‘framing’, see Michel Callon, ‘Actor Network Theory – The Market Test’, in Law & Hassard (eds), op. cit. note 3, 181–95.
 35. The Blair latrine is another improvement of a conventional device, in this case the pit latrine, developed in Zimbabwe. A latrine of very simple but particular construction, it

- deploys wind, solar radiation and the relative position of its elements to create air currents that keep it fly-free and odourless. Water is used to clean the latrine but is not necessary for its operation. In rural areas where water is scarce this is the latrine technology of choice.
36. A 1997 government initiative to reallocate land from wealthy white farmers to the rural poor has been analyzed in newspaper reports and scholarly commentaries as an effort to strengthen the withering support for Robert Mugabe's ruling coalition in Zimbabwe – and thus, as an exercise in nation-building.
 37. Morgan & Von Elling, *op. cit.* note 19, 29.
 38. Expecting completely fluid phenomena to 'work' is too romantic, while expecting mechanics of whatever kind to 'function' without any fluidity signals too great a belief in metrics: for a discussion of this point, see: John Law and Annemarie Mol, 'On Metrics and Fluids: Notes on Otherness', in Robert Chia (ed.), *Organized Worlds* (London: Routledge, 1998), 20–38.
 39. Morgan (1995), *op. cit.* note 32.
 40. Since the publication of the manual on which our technical description is based, the pump has evolved further. Morgan writes: 'The method of lifting the footvalve [on the bottom of the piston] through the rising main has been abandoned – the footvalve always became cemented in the base of the cylinder. The footvalve is not extractable, but is reliable and heavy duty': letter [b].
 41. Morgan, *op. cit.* note 12, ii.
 42. *Ibid.*, 14.
 43. There is another delicate balance here, which varies with circumstances and make-up of the community. As we will see below, a community may also be too *large* to maintain a pump properly.
 44. Incidentally, the wave of *E.coli* contamination in US hamburger meat in the summer of 1998 was so alarming not because the *E.coli* is in itself deadly, but because if it comes from a foreign body it may have deadly effect. And because hamburgers are eaten in great numbers, of course.
 45. This point has been highlighted by many others who investigated standardization. For an example in a medical setting, see Marc Berg, *Rationalizing Medical Work* (Cambridge, MA: MIT Press, 1997).
 46. It should be clear that we are by no means suggesting that a Bush Pump does *not*, in general, provide water with less *E.coli* than, say, a Bucket Pump!
 47. Note that our discussion eschews knowledge of what a 'community' 'is'; in other words, as we are interested in what happens when a pump enters a site, and argue that the pump contributes to shaping community, we do not seek to sort out which kind of user configurations will be likely to adopt the pump.
 48. But one more word on the users. The community is not necessarily the village. It therefore makes little sense to define what will be a workable unit in advance; the failure of some water pumps on the village level, and the occasional regrouping of family units around this technology, suggests that the units form in the process itself – which is, of course, old technology studies wisdom. For an early articulation, see Michel Callon, 'Struggles and Negotiations to Define what is Problematic and what is Not: The Socio-logics of Translation', in Karin Knorr, Roger Krohn and Richard Whitley (eds), *The Social Process of Scientific Investigation* (Dordrecht: Reidel, 1980), 197–220.
 49. Aligning the number of users with a pump is also a matter of cost. The Bush Pump is not only more difficult to maintain than the Bucket Pump; it is also more expensive. Since villagers are expected to contribute towards the purchase price of a pump, the installation of a Bush Pump requires a larger user population. Even if there were no village contribution to the cost, a certain number of people is needed to convince the government (or other subsidizing institution) that a Bush Pump is a sound investment. So, while a smaller number of users may guarantee more careful maintenance of the pump, the Bush Pump's cost may be prohibitive for such a small community.

50. See Morgan et al., op. cit. note 29, 8. Whereas the government was still reluctant to adopt the programme in 1996, by early 1998 it had been convinced of its value: Morgan, letter [b].
51. As would organizations like UNICEF which, having been enticed (by whatever means) to employ the Bush Pump in Zimbabwe, are now adopting the pump for wider use.
52. The relation of authorship and ownership has been more thoroughly analyzed for copyright than for patents: see, for instance, Laura Rosenthal, '(Re)Writing Lear: Literary Property and Dramatic Authorship', and Julie Stone Peters, 'The Bank, the Press, and the Return of "Nature": Of Currency, Credit, and Literary Property in the 1690s', both in John Brewer & Susan Staves (eds), *Early Modern Conceptions of Property* (London: Routledge, 1997), 323–38, 365–88; also Mark Rose, *Authors and Owners: The Invention of Copyright* (Cambridge, MA: Harvard University Press, 1993), and Robert Merger, *Patent Law and Policy* (Charlottesville, VA: Michie, 1992).
53. Latour, op. cit. note 10.
54. This is controversial. Recall Aristotle's critique of Plato: 'that which belongs to everybody belongs to nobody'. Moreover, advocates of patenting dispute the validity of such calculation, arguing that if novel technology is not patented the producer will have to calculate costs deriving from attempts by others to produce copies of the technology at a lower price. According to such arguments, there is a 'social cost' attached, for instance if copying the product results in consumers settling for unpatented, less preferred products that are sold at competitive prices. See Paul David, 'Intellectual Property Institutions and the Panda's Thumb', in Mitchel B. Wallerstein, Mary Ellen Mogee and Roberta A. Schoen (eds), *Global Dimensions of Intellectual Property Rights in Science and Technology* (Washington, DC: National Academy Press, 1993), 19–61.
55. P. Morgan, 'Small Steps Count – Building on Traditional Methods for Rural Water Supply', *Waterlines*, Vol. 15, No. 3 (January 1997), 2–5, at 2.
56. On Morgan's part, that is. The government's current upgrading and installation programme *does* include a modest effort to monitor its pumps.
57. In our reflections on the kind of masculinity that Morgan (re-)presents we have also been inspired by another, slightly different version of it, that of the novelist Paul Auster. Auster's version is cast as an implicit rejection of, and a creative alternative to, what in the USA is called a 'WASP'. See, for example, P. Auster, *The Invention of Solitude* (New York: Penguin USA, 1988); or Auster, *Hand to Mouth: A Chronicle of Early Failure* (London: Faber & Faber, 1997).
58. This remark is of a public, not a private nature. We do not mean to say anything about Peter Morgan, in a personal sense; to us, his modesty is not a personality trait. For though interviewing him was much fun (and, to be sure, not all interviewing is!), we cannot claim to know him 'personally'. With 'ideal man', here, we refer to Dr Morgan, a public figure in the space of technology design and water politics. What we are up to is not to intrude into a private life, but to mobilize terms that are coined in the private sphere, and put them to use in relation to public issues. With this move we situate ourselves in the tradition of feminist scholarship, where it has been done before: see, for example, Sara Ruddick, 'Maternal Thinking', in Joyce Trebilcock (ed.), *Mothering: Essays in Feminist Theory* (Totowa, NJ: Rowman & Allanheld, 1984), 213–30. But we may also link ourselves in a footnote to Luc Boltanski's work on *agape*. Boltanski draws attention to forms of self-effacing love that operate in the public domain, however much the tradition of critical sociology has always denounced any reference to them as misleading ideology: see L. Boltanski, *L'Amour et la Justesse comme compétences* (Paris: Editions Métailié, 1990).
59. The trope of the love for technologies is brought into play by Bruno Latour in his *Aramis, ou l'amour des techniques* (Paris: Editions la Découverte, 1993). Latour, however, is a bit vague as to his object of love. Is it Aramis, of which he lists such wonderful characteristics? Or does he indeed ask us to love *technology* in general? That seems too humanist a requirement to us, and moreover a missed chance to separate out what is lovable from what is not.

60. See, for example, Wiebe Bijker and John Law, 'General Introduction', in Bijker & Law (eds), op. cit. note 4, 1–14. Bijker and Law argue that the technical is always, and at the same time, social and *vice versa*: the social and the technical are not two different and separate realms.
61. For a discussion of how an object contains its environment, see, for instance, Michel Serres, *Hermès V: Le Passage du Nord-Ouest* (Paris: Editions Minuit, 1980), published in English translation as *Hermes: Literature, Science, Philosophy* (Baltimore, MD: Johns Hopkins University Press, 1982). Here, as in many other places, Serres describes how the nature of an object varies with the methods by which it is measured, assessed or appropriated. There is, for instance, no 'length' of the coast of Brittany, Serres argues, for the length of the coastline followed by foot is different from that covered by following the highway; from the water the coastal length is yet quite another matter. Not only is the *distance* different in each of these instances; each length, by including its specific mode of measurement, is a different *thing*. Likewise, the Bush Pump contains its environment: it is a different thing when it is sitting on the premises of V&W Engineering, than it is when pouring water in, say, Marondera.
62. We may have learned this from the Bush Pump, but it is a fairly classical argument. That redundancy is a good trait in technologies has for instance been said in respect of military technologies, which are supposed to carry on working in 'extreme' circumstances: see John Law, *Aircraft Stories: Decentering the Object in Technoscience* (Durham, NC: Duke University Press, forthcoming, 2001).
63. In his history of the cross-over between ethnomethodology and science studies, Michael Lynch examines how *ethnomethodology* takes as its object the local organization of social activities, thereby offering an alternative to phenomenological accounts that are based on a psychology of consciousness: see M. Lynch, *Scientific Practice and Ordinary Action: Ethnomethodology and Social Studies of Science* (Cambridge: Cambridge University Press, 1993), esp. Chapter 4. For this argument, see also Jonathan Potter and Margaret Wetherell's wonderful 'guide' to discourse analysis: *Discourse and Social Psychology: Beyond Attitudes and Behaviour* (London: Sage, 1987). In analogy with this move away from the conscious subject, what may be needed in S&TS now is an alternative to the generalized ethics of the responsible subject; a – how to say it – *topoi-ethicality* that points to what may be good in local arrangements, and that explores what happens when elements from these localities start to travel.
64. Whereas in a mythical past, before S&TS, epistemology structured all thoughts in relation to science, approaching 'false' and 'true' statements in a symmetrical way has been highly liberating. However, such neutralizing moves shouldn't lead to *general bans* on normativity, but only to bans on *general normativity*. One of the more urgent tasks for S&TS seems, to us, the reassessment of the character of normativity itself. For an attempt, see Jim Collier, *The Nature of Metascientific Claims* (unpublished PhD dissertation, Department of Science and Technology Studies, Virginia Tech, 1998).
65. Standpoints and points of contrast are not necessarily points of departure. They may be acquired or changed in the process of engaging with a subject, an object or a topic. So rather than a *standpoint epistemology*, however subtly it may be handled, we would like to develop a *travel-bag normativity* that can be taken along and fluidly adapted. For a nuanced version of the former, see Donna Haraway, *Simians, Cyborgs, and Women* (New York: Routledge, 1991). And for some elements towards the latter, see George Robertson, Melinda Mash, Lisa Tickner, John Bird, Barry Curtis and Tim Putman (eds), *Travellers' Tales: Narratives of Home and Displacement* (London: Routledge, 1994).
66. Not every interpellation, however, should be taken as a reason for praise. In good Althusserian fashion, one may doubt whatever one is seduced by. For an example of this, analyzing various relations between men and machines, see John Law, 'Machinic Pleasures and Interpellations', in Brita Brenna, Law and Ingunn Moser (eds), *Machines, Agency and Desire* (Oslo: University of Oslo, TMV-report, 1998).

Marianne de Laet is an anthropologist of science and technology, and currently a Senior Researcher in the Division of the Humanities and Social

Sciences at the California Institute of Technology. Her research concerns intellectual property, appropriate technology and technology transfer. The present paper was written and researched while she was a Research Fellow of the Netherlands Organization for Scientific Research, and a Visiting Assistant Professor of Science and Technology Studies in the Department of Civil Engineering and Engineering Mechanics at Columbia University's School of Engineering and Applied Science.

Address: HSS 228-77, 331-C Baxter, California Institute of Technology, Pasadena, California 91125, USA; fax: +1 626 793 8580; email: delaet@its.caltech.edu

Annemarie Mol is Socrates Professor of Political Philosophy at the University of Twente for one day a week, and otherwise depends on temporary research grants. She engages in 'empirical philosophy', mainly in relation to medicine and health care. With Marc Berg she recently edited *Differences in Medicine: Unravelling Practices, Techniques and Bodies* (Duke University Press, 1998). Her single-authored book, *The Body Multiple: Ontology in Medical Practice*, will soon appear, also with Duke University Press.

Address: W. de Zwijgerstraat 25, NL-3583 Utrecht, The Netherlands; email: a.mol@wmw.utwente.nl